

# NUCLEO



HOME COLLECTION  
2025 / 2026

Tables - Coffee Tables - Chairs - Consolle



# CALLA

Art. 00-20 pag. 31

Base Ø 100 Bianco Bucciato

Piano tavolo Ø120 CM

marmo Travertino Classico Opaco (M3)

Sedie Willow struttura in legno Rovere

seduta e schienale cat.A cod.788-315

Madia Madrid Castagno Naturale

ripiano in gres travertino opaco



# DAHALIA

Art. 00-15 pag. 28

Base Ø 80 in Bronzo Metallizzato

Piano tavolo Ø 130 cm

marmo naturale Arabescato (M4)

Sedie Medlar scocca in legno nero  
seduta e schienale cat. B cod.786-001



# DAISY

Art. 00-25 pag. 34

Base Ø 60 Bianco Bucciato

Piano tavolo Ø130 CM

marmo naturale Bianco Carrara (M1)

sedia Mimosa\_B scocca bianco bucciato

seduta legno Bianco



# TULIPANO

Art. 00-10 pag. 13

Base Tulipano bianco lucido Ø 50 cm

Piano tavolo Ø 160 cm

marmo naturale Bianco Carrara opaco (M1)

Sedie tulipano Nylon bianco lucido

cuscino in tessuto cat.V serie Adone cod.TM070\_20

Tavolino Tulipano bianco lucido Ø 43 cm

Piano tavolino Ø 50 cm

marmo naturale Bianco Carrara opaco (M1)



# IRIS

Art. 00-30 pag. 37

Base doppia Ø 81.7 nero bucciato

Piano tavolo 240x110 cm

gres Calacatta Oro (C2)

Sedie Cypress B scocca in bronzo metallizzato  
seduta e schienale in tessuto cat.A cod.788-409



# CLOVER

Art. 00-30 pag. 40

Base Ø 60 cm nero bucciato

Piano tavolo Ø 140 cm

marmo naturale Calacatta (M4)

Sedie Ginger scocca in nero bucciato  
seduta e schienale in legno nero



# ROOT

Art. 00-30 pag. 49

Base 101.5x45.5 cm in legno naturale

Piano tavolo 200x100 cm

marmo naturale Emperador (M2)

Sedie Maple scocca in legno naturale

seduta e schienale in tessuto cat.B cod.787-002

Consolle Londra in legno naturale

ripiani in marmo naturale Emperador (M2)



# CLOVER WOOD

Art. 00-30 pag. 43

Base Ø102.5 in legno noce chiaro

Piano tavolo Ø 160 cm

marmo naturale Breccia Rosa (M3)

Sedie Willow scozza in legno noce chiaro

seduta e schienale in tessuto cat.B cod.784-615



# SQUARE

Art. 00-30 pag. 52

Base 180x90 cm in nero bucciato

Piano tavolo 190x110 cm

Gres materico Pietra di Cardoso Nero (C3)

Sedie Cypress scocca nero bucciato

seduta e schienale in tessuto cat.A cod.788-409



# STEM

Art. 00-30 pag. 46

Base Ø 53 cm in legno noce scuro

Piano tavolo Ø 150 cm

marmo naturale nero marquinia (M2)

Sedie Maple scocca nero bucciato

seduta e schienale in tessuto cat.B cod. 787-003



BRAND	pag. 4
CATALOGO CATALOGUE	pag. 7
TULIPANO	pag. 13
TAVOLI FISSI FIXED TABLES	pag. 27
TAVOLI ALLUNGABILI EXTENDABLE TABLES	pag. 55
CONSOLLE CONSOLLE	pag. 65
TAVOLINI COFFEE TABLES	pag. 91
SEDIE CHAIRS	pag. 121
FINITURE FINISHES	pag. 133
• MATERIALI PER TOP TAVOLO TABLETOP MATERIALS	
• MATERIALI E COLORI PER TAVOLI E SEDIE MATERIAL AND COLOR FOR TABLE AND CHAIRS	
• PROFILI TOP TAVOLO TABLETOP EDGES	
LISTINI TOP TOP PRICE LIST	pag. 153
• TOP TAVOLI MARMO - CERAMICA - QUARZO - AGG. TERRAZZO TABLE TOP MARBLE - CERAMIC - QUARTZ - AGG. TERRAZZO	
• CORNICI TAVOLI FRAMES TABLES	
CURA E MANUTENZIONE CARE AND MAINTENANCE	pag. 157
NOTE	pag. 157

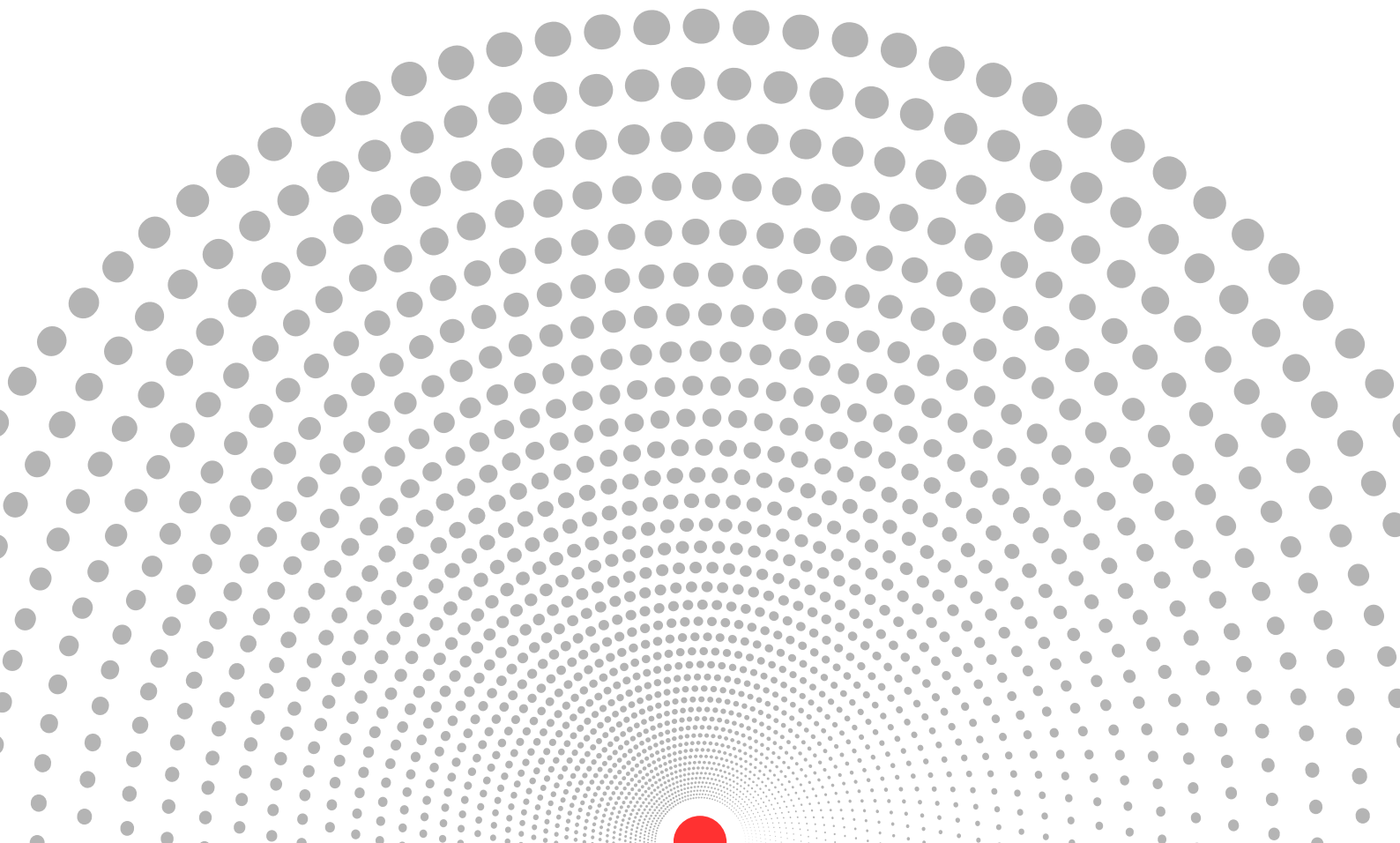

Nucleo

# Brand

2025

---

# Su di noi

## About us

**NUCLEO** è il nuovo brand che entra a far parte del gruppo Serra marmi, avvalendosi delle capacità produttive ed organizzative dell'azienda gestita interamente e direttamente dalla famiglia Serra che, da tre generazioni, produce e fornisce i più importanti brand di arredo e design.

La nostra esperienza ci permette di rimanere sempre al passo delle mode ed al tempo stesso di creare personalizzazioni grazie alla vastità di colori disponibili e la possibilità di realizzare pezzi unici su misura forti della nostra produzione interna.



NUCLEO is the new brand that joins the Serra marmi group, taking advantage of the production and organizational capabilities of the company managed entirely and directly by the Serra family which has been producing and supplying the most important furniture and design brands for three generations. Our experience allows us to always keep up with fashion trends and at the same time create customizations thanks to the vastness of available colors and the possibility of creating unique tailor-made pieces thanks to our internal production.

# Il Brand Nucleo..perché?

Desideriamo creare bellezza personalizzata per rispondere ai gusti di tutti.

Avrete così l'opportunità di vivere e presentare il Vostro oggetto al CENTRO del Vostro spazio, grazie alla nostra ricerca nel design e alla possibilità di personalizzarlo per forma, colore e dimensione.



## Nucleo..why?

We want to create personalized beauty to suit everyone's tastes.

You will have the opportunity to live and present your object at the CENTER of your space, thanks to our research in design and the possibility of customizing it in shape, color and size.





Nucleo

# Catalogo

## Catalogue

2025

---

# TAVOLI

TABLES



**Tulipano**  
pag. 13



**Clover**  
pag. 40



**Dahlia**  
pag. 28



**Clover Wood**  
pag. 43



**Calla**  
pag. 31



**Stem**  
pag. 45



**Daisy**  
pag. 34



**Root**  
pag. 49



**Iris**  
pag. 37



**Square**  
pag. 52

# TAVOLI ALLUNGABILI

## EXTENDABLE TABLES



Summer  
pag. 56



Falcon  
pag. 58



Spring  
pag. 60



Eagle  
pag. 62

# MADIE - CONSOLLE

## SIDEBOARDS - CONSOLE TABLES



Madrid  
pag. 66



Parigi  
pag. 74



Vienna  
pag. 78



Londra  
pag. 81



Berlino  
pag. 86

# TAVOLINI

## COFFEE TABLES



**Tulipano**  
pag. 18



**Rose**  
pag. 102



**Dahlia B**  
pag. 92



**Leaf**  
pag. 104



**Calla B**  
pag. 94



**Stone**  
pag. 108



**Iris B**  
pag. 96



**Cube**  
pag. 111



**Stem B**  
pag. 98



**Corner**  
pag. 113



**Violet**  
pag. 100



**Trendy**  
pag. 117

# SEDIE CHAIRS



**Tulipano**

pag. 19 - 20



**Willow**

pag. 127



**Maple**

pag. 122 - 123



**Medlar**

pag. 127



**Pine**

pag. 123



**Cypress**

pag. 128 - 129



**Poplar**

pag. 124 - 125



**Mimosa**

pag. 130 - 131



**Palm**

pag. 126



**Ginger**

pag. 131



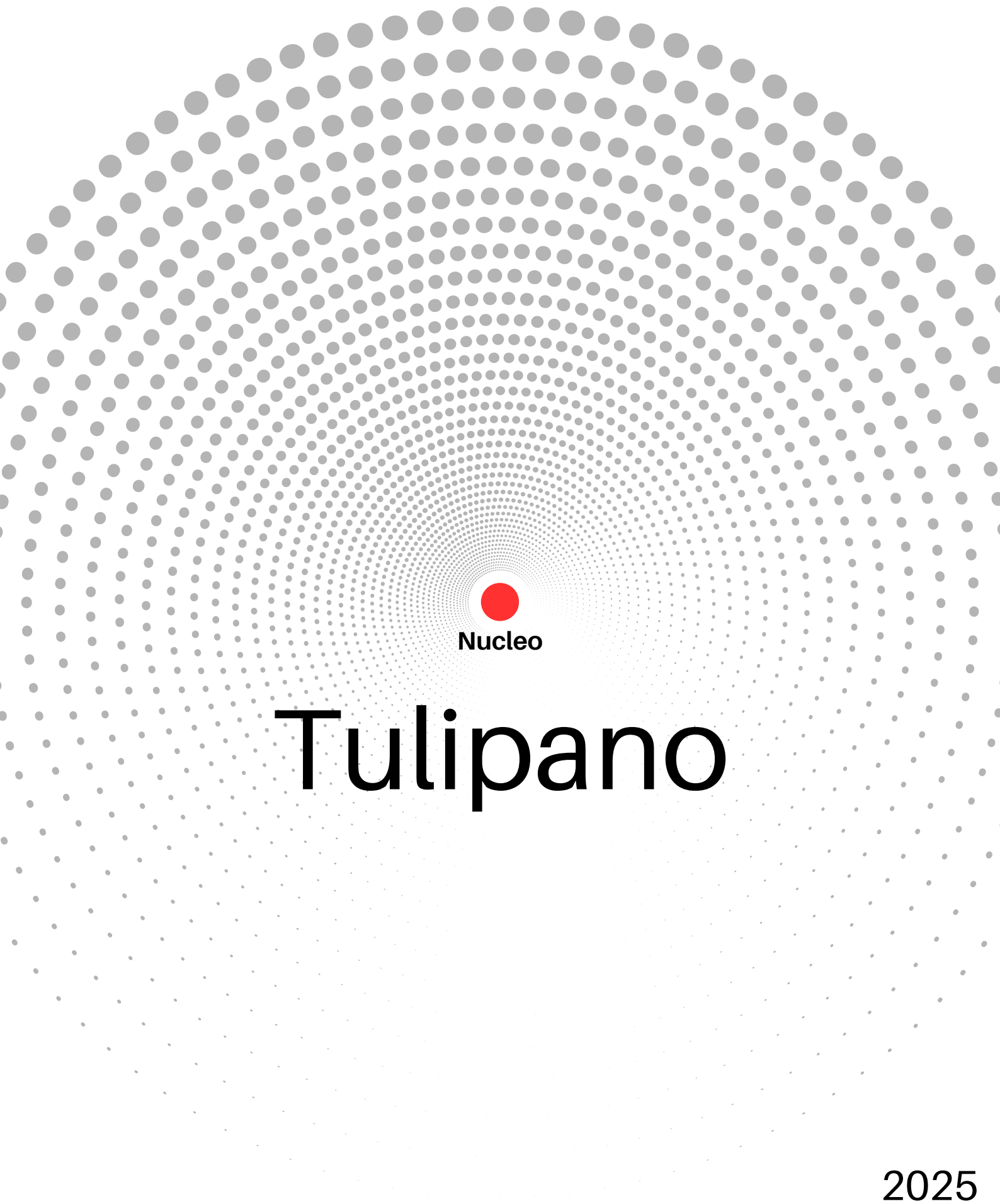

Nucleo

# Tulipano

2025

---



# TULIPANO

Art. 00-10

Icona del design, innovativo nella forma elegante e raffinata. Un tavolo che è un elemento di eccezionale praticità e bellezza, ovale o tondo, da utilizzare come tavolo da pranzo, soggiorno o coffee table, con un'unica base centrale che libera lo spazio circostante.

Icon of design, innovative in its elegant and refined form. A table that is an element of exceptional practicality and beauty, oval or round, to be used as a dining table, living room or coffee table, with a single central base that frees up the surrounding space.

COLORE STRUTTURA STANDARD - STANDARD STRUCTURE COLOR

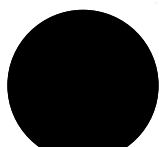

Nero  
Lucido

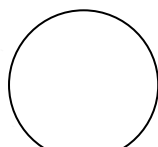

Bianco  
Lucido

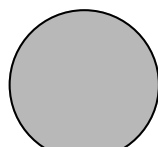

Grigio  
Opaco

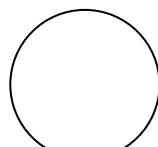

Bianco  
Opaco

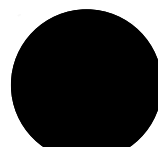

Nero  
Opaco



TULIPANO

## Art. 00-10-01

Base  $\varnothing$  43 cm  
Struttura in fusione unica alta 71 cm per tavolo fisso  
Colore standard  
Top tavolo escluso

Base  $\varnothing$  43 cm  
Single cast structure 71 cm high for fixed table  
Standard color  
Table top not included

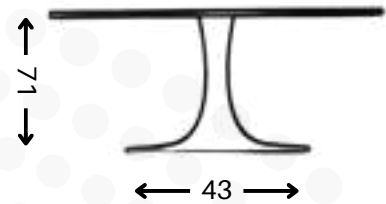

### Forme e dimensioni top possibili



## Art. 00-10-02

Base  $\varnothing$  50 cm  
Struttura in fusione unica alta 71 cm per tavolo fisso  
Colore standard  
Top tavolo escluso

Base  $\varnothing$  50 cm  
Single cast structure 71 cm high for fixed table  
Standard color  
Table top not included

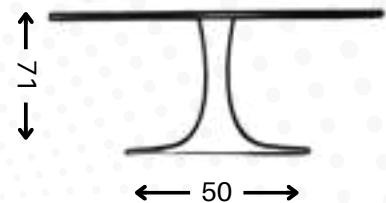

### Forme e dimensioni top possibili

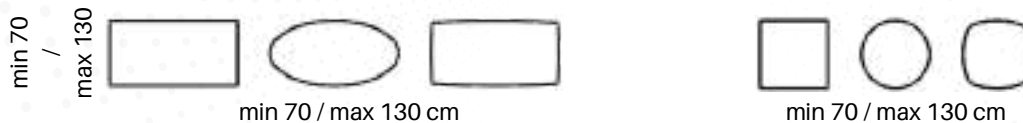

## Art. 00-10-03

Base  $\varnothing$  70 cm  
Struttura in fusione unica alta 71 cm per tavolo fisso  
Colore standard  
Top tavolo escluso

Base  $\varnothing$  70 cm  
Single cast structure 71 cm high for fixed table  
Standard color  
Table top not included

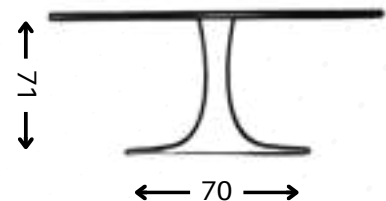

### Forme e dimensioni top possibili

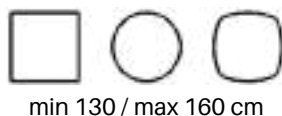

## Art. 00-10-04

Base ovale **79x59 cm**

Struttura in fusione unica alta **71 cm** per tavolo fisso

Colore standard

Top tavolo escluso

Oval base **79x59 cm**

Single cast structure **71 cm** high for fixed table

Standard color

Table top not included

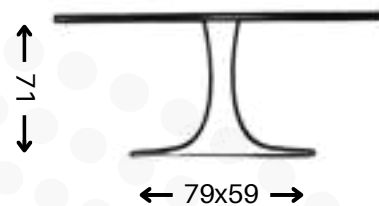

### Forme e dimensioni top possibili

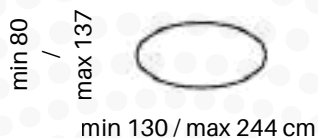

## Art. 00-10-05

Base ovale **100x75 cm**

Struttura in fusione unica alta **71 cm** per tavolo fisso

Colore standard

Top tavolo escluso

Oval base **100x75 cm**

Single cast structure **71 cm** high for fixed table

Standard color

Table top not included

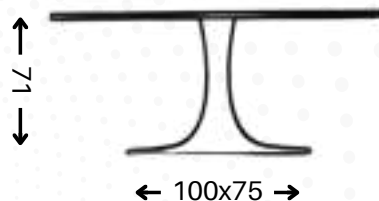

### Forme e dimensioni top possibili



## Art. 10-10-01

Base  $\varnothing$  43 cm

Struttura in fusione unica alta 39 cm per tavolo fisso

Colore standard

Top tavolo escluso

Base  $\varnothing$  43 cm

Single cast structure 39 cm high for fixed table

Standard color

Table top not included

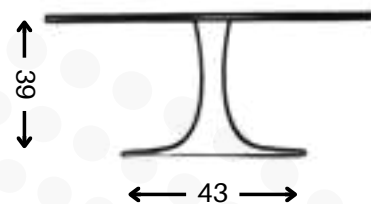

### Forme e dimensioni top possibili



min 60 / max 90 cm

## Art. 10-10-02

Base ovale 56x41 cm

Struttura in fusione unica alta 39 cm per tavolo fisso

Colore standard

Top tavolo escluso

Oval base 56x41 cm

Single cast structure 39 cm high for fixed table

Standard color

Table top not included

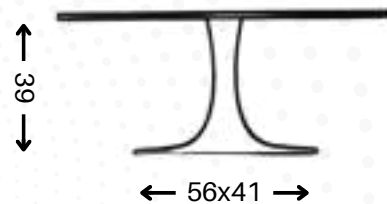

### Forme e dimensioni top possibili



min 100 / max 120 cm

## Tulipano FiberGlass

art. 20-10-01

Sedia con basamento rotondo in fusione di alluminio laccato lucido o opaco, scocca in vetroresina con cuscino schiumato.

Chair with round base in glossy or matt lacquered cast aluminium, fiberglass shell with foam cushion.



Tessuti Seduta cat. T e cat. ECO  
Seat Fabrics cat. T e cat. ECO

Tessuti Seduta cat. V  
Seat Fabrics cat. V

Tessuti Seduta cat. PA  
Seat Fabrics cat. PA

### Scegli il tuo stile - Choose your style

Colori Struttura - standard Tulipano

Structure Colors - standard Tulipano.....pag. 21

Colori Seduta - sedie Tulipano

Seat Colors - Chair Tulipano.....pag. 22 -26



## Tulipano Nylon

art. 20-10-02

Sedia con basamento rotondo in fusione di alluminio laccato lucido o opaco, scocca in nylon con cuscino schiumato.

Chair with round base in glossy or matt lacquered cast aluminium, nylon shell with foam cushion.

Tessuti Seduta cat. T e cat. ECO  
Seat Fabrics cat. T e cat. ECO

Tessuti Seduta cat. V  
Seat Fabrics cat. V

Tessuti Seduta cat. PA  
Seat Fabrics cat. PA

### Scegli il tuo stile - Choose your style

Colori Struttura - standard Tulipano

Structure Colors - standard Tulipano.....pag. 21

Colori Seduta - sedie Tulipano

Seat Colors - Chair Tulipano.....pag. 22 - 26

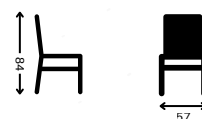



## Tulipano Chair B

art. 20-10-03

Sedia con basamento rotondo in fusione di alluminio laccato lucido o opaco, scocca in vetroresina con schienale rivestito in tessuto e cuscino schiumato.

Chair with round base in gloss or matt lacquered cast aluminum, fiberglass shell with backrest covered in fabric and foamed cushion.

Tessuti Seduta cat. T  
Seat Fabrics cat. T

Tessuti Seduta cat. V  
Seat Fabrics cat. V

Tessuti Seduta cat. PA  
Seat Fabrics cat. PA

### Scegli il tuo stile - Choose your style

Colori Struttura - standard Tulipano  
Structure Colors - standard Tulipano.....pag. 21

Colori Seduta - sedie Tulipano  
Seat Colors - Chair Tulipano.....pag. 22 - 26



## Tulipano Armchair

art. 20-10-04

Poltrona con basamento rotondo in fusione di alluminio laccato lucido o opaco, scocca in vetroresina con cuscino schiumato.

Armchair with round base in gloss or matt lacquered cast aluminum, fiberglass shell with foamed cushion.

Tessuti Seduta cat. T cat. ECO  
Seat Fabrics cat. T e cat. ECO

Tessuti Seduta cat. V  
Seat Fabrics cat. V

Tessuti Seduta cat. PA  
Seat Fabrics cat. PA

### Scegli il tuo stile - Choose your style

Colori Struttura - standard Tulipano  
Structure Colors - standard Tulipano.....pag. 21

Colori Seduta - sedie Tulipano  
Seat Colors - Chair Tulipano.....pag. 22 - 26

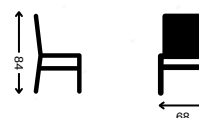

# Finiture Tulipano

Strutture Tavoli e Sedute  
Tables Structures and Chairs

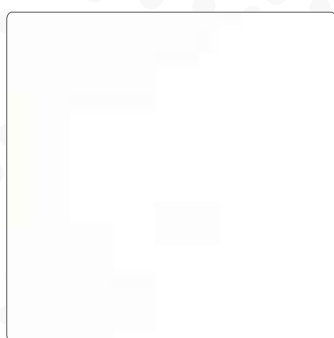

Bianco Opaco 01  
White Matt 01

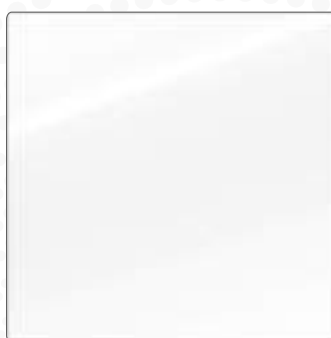

Bianco Lucido 02  
White Glossy 02



Nero Opaco 03  
Black Matt 03

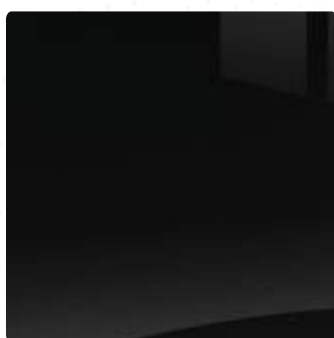

Nero Lucido 04  
Black Glossy 04



Grigio Opaco 05  
Grey Matt 05

Per le sedie il piede è disponibile in tutte le finiture, la scocca in nylon solo in Bianco Lucido, mentre la scocca in vetroresina solo in Bianco Opaco o Nero Opaco.

For the chairs the foot is available in all finishes, the nylon shell only in Glossy White, while the fiberglass shell only in Matt White or Matt Black.

**Cat. T - Tessuti Sedie modello Tulipano serie JET**

**Cat. T - Fabrics Chairs model Tulipano series JET**



**Cat. T - Tessuti Sedie modello Tulipano serie MAYA**

**Cat. T - Fabrics Chairs model Tulipano series MAYA**



**Cat. PA - Pelle Sedie modello Tulipano serie SUAVE**

**Cat. PA - Leather Chairs model Tulipano series SUAVE**



**Cat. PA - Pelle Sedie modello Tulipano serie KELLY**

**Cat. PA - Leather Chairs model Tulipano series KELLY**



**Cat. ECO - Similpelle Ignifuga Sedie modello Tulipano serie TOUCH**

**Cat. ECO - Fireproof Faux Leather Chairs model Tulipano series TOUCH**

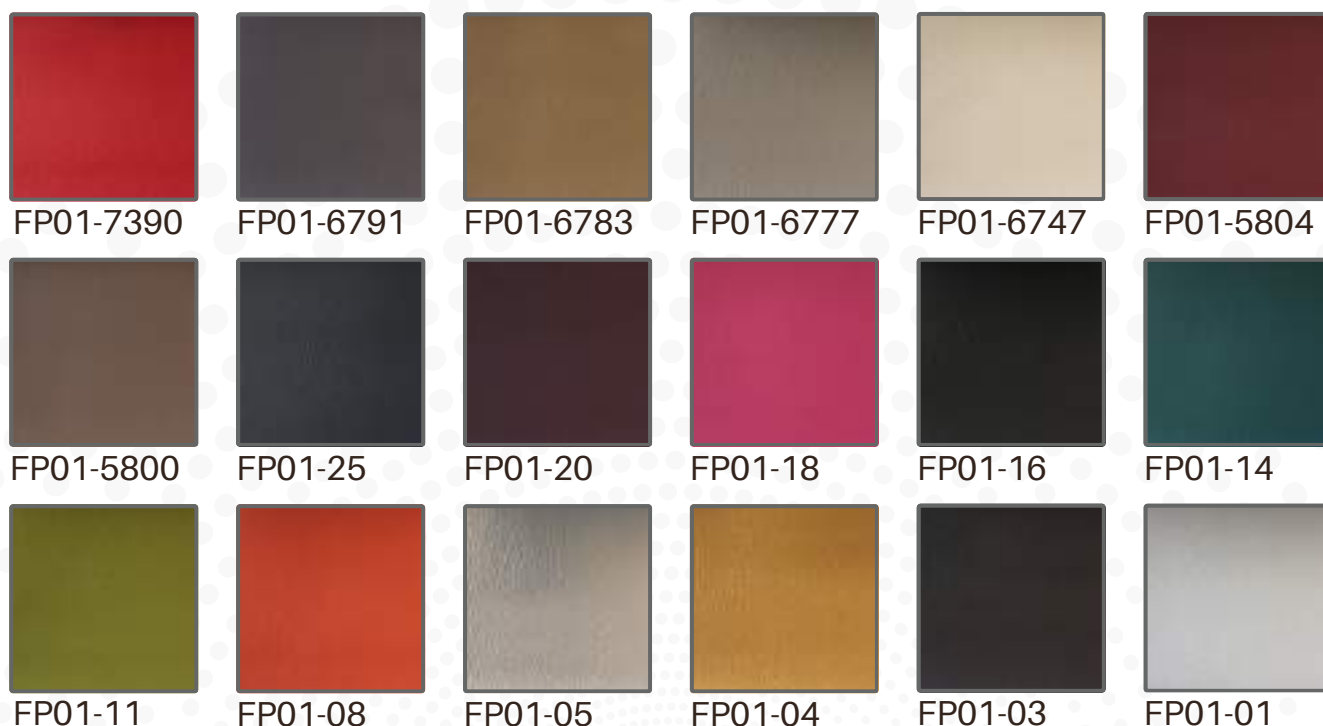

**Cat. V - Velluto Sedie modello Tulipano serie ADONE**

**Cat. V - Velvet Chairs model Tulipano series ADONE**





Nucleo

# Tavoli Fissi

## Fixed Tables

2025

---



# DAHALIA

Art. 00-15

La struttura circolare in acciaio e le curve armoniose degli archi conferiscono un tocco di eleganza a questo tavolo, adattandosi a qualsiasi ambiente e creando uno stile raffinato e moderno.

The circular steel structure and the harmonious curves of the arches give a touch of elegance to this table, adapting to any environment and creating a refined and modern style.

## COLORE STRUTTURA STANDARD - STANDARD STRUCTURE COLOR



Bronzo  
Metallizzato



Rame  
Metallizzato



Alluminio  
Goffrato



Avorio  
Opaco



Beige  
Grigio

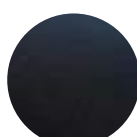

Nero  
Bucciato



Bianco  
Bucciato

## Art. 00-15-01

Base  $\varnothing$  80 cm con massima apertura  $\varnothing$  105 cm  
Struttura in acciaio alta 74 cm per tavolo fisso  
Colore standard  
Top tavolo escluso

Base  $\varnothing$  80 cm with maximum opening  $\varnothing$  105 cm  
Steel structure 74 cm high for fixed table  
Standard color  
Table top not included

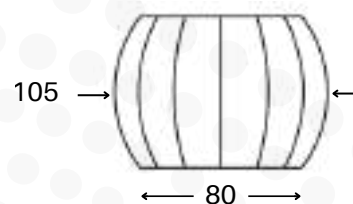

### Forme e dimensioni top possibili



## Art. 00-15-02

Base  $\varnothing$  100 cm con massima apertura  $\varnothing$  125 cm  
Struttura in acciaio alta 74 cm per tavolo fisso  
Colore standard  
Top tavolo escluso

Base  $\varnothing$  100 cm with maximum opening  $\varnothing$  125 cm  
Steel structure 74 cm high for fixed table  
Standard color  
Table top not included

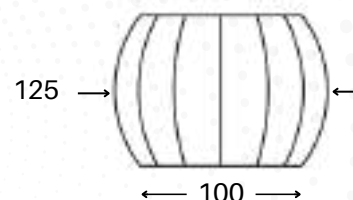

### Forme e dimensioni top possibili



FINITURE TOP TAVOLO PAG. 133 - PREZZI TOP TAVOLO PAG. 153  
TABLE TOP FINISHES PAG. 133 - TABLE TOP PRICES PAG. 153



DAHALLIA



# CALLA

Art. 00-20

Questo tavolo moderno e contemporaneo in acciaio sfrutta le forme per creare un intreccio di ombre e linee vuote che riempiono l'ambiente.

This modern and contemporary steel table uses shapes to create a weave of shadows and empty lines that fill the space.

## COLORE STRUTTURA STANDARD - STANDARD STRUCTURE COLOR



Bronzo  
Metallizzato



Rame  
Metallizzato



Alluminio  
Goffrato



Avorio  
Opaco



Beige  
Grigio

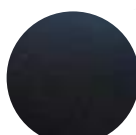

Nero  
Bucciato



Bianco  
Bucciato

## Art. 00-20-01

Base  $\varnothing$  80 cm con minima apertura  $\varnothing$  40 cm  
Struttura in acciaio alta 74 cm per tavolo fisso  
Colore standard  
Top tavolo escluso

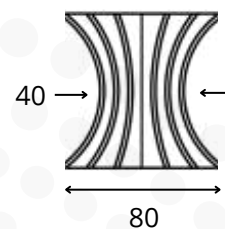

Base  $\varnothing$  80 cm with minimum opening  $\varnothing$  40 cm  
Steel structure 74 cm high for fixed table  
Standard color  
Table top not included

### Forme e dimensioni top possibili

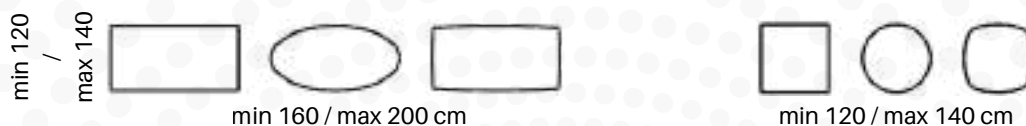

## Art. 00-20-02

Base  $\varnothing$  100 cm con minima apertura  $\varnothing$  50 cm  
Struttura in acciaio alta 74 cm per tavolo fisso  
Colore standard  
Top tavolo escluso

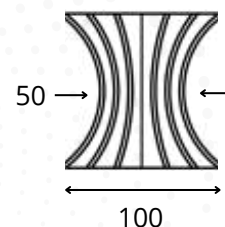

Base  $\varnothing$  100 cm with minimum opening  $\varnothing$  50 cm  
Steel structure 74 cm high for fixed table  
Standard color  
Table top not included

### Forme e dimensioni top possibili

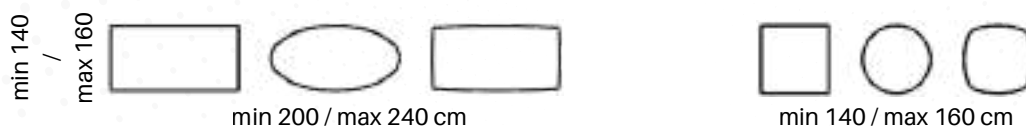

FINITURE TOP TAVOLO PAG. 133 - PREZZI TOP TAVOLO PAG. 153  
TABLE TOP FINISHES PAG. 133 - TABLE TOP PRICES PAG. 153



CALLA



# DAISY

Art. 00-25

Questo tavolo minimalista è un mix di semplicità e modernità. Una solida ma armoniosa struttura in acciaio sostiene un piano che diventa il fulcro dell'intero design.

This minimalist table is a mix of simplicity and modernity. A solid but harmonious steel structure supports a top that becomes the centerpiece of the entire design.

## COLORE STRUTTURA STANDARD - STANDARD STRUCTURE COLOR



Bronzo  
Metallizzato



Rame  
Metallizzato



Alluminio  
Goffrato



Avorio  
Opaco



Beige  
Grigio



Nero  
Bucciato



Bianco  
Bucciato

## Art. 00-25-01

Base  $\varnothing$  60 cm con minima apertura  $\varnothing$  20 cm  
Struttura in acciaio alta 73.5 cm per tavolo fisso  
Colore standard  
Top tavolo escluso

Base  $\varnothing$  60 cm with minimum opening  $\varnothing$  20 cm  
Steel structure 73.5 cm high for fixed table  
Standard color  
Table top not included

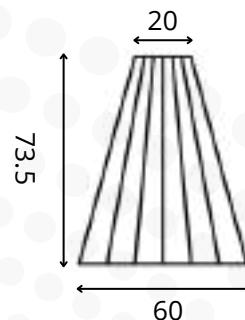

Forme e dimensioni top possibili



min 120 / max 130 cm

## Art. 00-25-02

Due basi  $\varnothing$  60 cm con minima apertura  $\varnothing$  20 cm  
Struttura in acciaio alta 73.5 cm per tavolo fisso  
Colore standard  
Top tavolo escluso

Two bases  $\varnothing$  60 cm with minimum opening  $\varnothing$  20 cm  
Steel structure 73.5 cm high for fixed table  
Standard color  
Table top not included

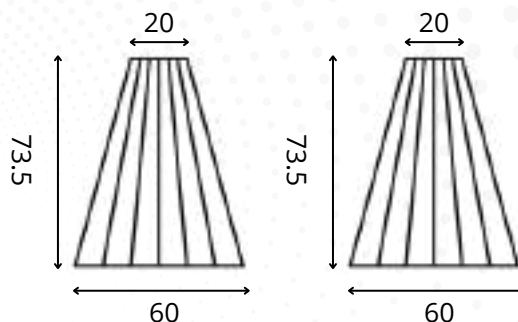

Forme e dimensioni top possibili



min 200 / max 240 cm

FINITURE TOP TAVOLO PAG. 133 - PREZZI TOP TAVOLO PAG. 153  
TABLE TOP FINISHES PAG. 133 - TABLE TOP PRICES PAG. 153



DAISY



# IRIS

Art. 00-30

La caratteristica di questo tavolo è la geometria delle linee, evidenziata dalla sua base conica in acciaio che consente di sperimentare con la forma del piano, per creare un insieme di forme e dimensioni affascinanti.

The characteristic feature of this table is the geometry of its lines, highlighted by its conical steel base that allows you to experiment with the shape of the top, to create a set of fascinating shapes and sizes.

## COLORE STRUTTURA STANDARD - STANDARD STRUCTURE COLOR

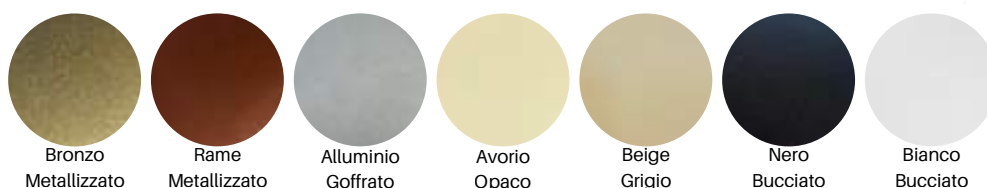

Bronzo  
Metallizzato

Rame  
Metallizzato

Alluminio  
Goffrato

Avorio  
Opaco

Beige  
Grigio

Nero  
Bucciato

Bianco  
Bucciato

## Art. 00-30-01

---

Base  $\varnothing$  81.7 cm con minima apertura  $\varnothing$  30 cm  
Struttura in acciaio alta 72.5 cm per tavolo fisso  
Colore standard  
Top tavolo escluso

---

Base  $\varnothing$  81.7 cm with minimum opening  $\varnothing$  30 cm  
Steel structure 72.5 cm high for fixed table  
Standard color  
Table top not included

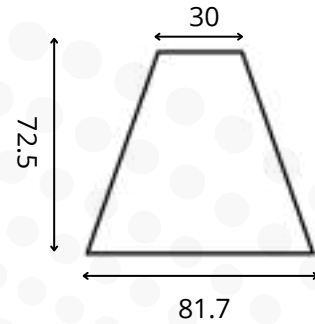

### Forme e dimensioni top possibili



## Art. 00-30-02

---

Due basi  $\varnothing$  81.7 cm con minima apertura  $\varnothing$  30 cm  
Struttura in acciaio alta 72.5 cm per tavolo fisso  
Colore standard  
Top tavolo escluso

---

Two bases  $\varnothing$  81.7 cm with minimum opening  $\varnothing$  30 cm  
Steel structure 72.5 cm high for fixed table  
Standard color  
Table top not included

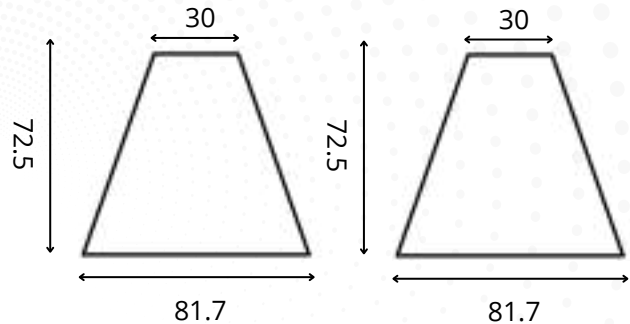

### Forme e dimensioni top possibili



FINITURE TOP TAVOLO PAG. 133 - PREZZI TOP TAVOLO PAG. 153  
TABLE TOP FINISHES PAG. 133 - TABLE TOP PRICES PAG. 153



IRIS



# CLOVER

Art. 00-35

Maestoso ma fluido, questo tavolo diventa il centro della stanza grazie alla sofisticata combinazione dei cilindri in acciaio che gli conferiscono stabilità ed armonia.

Majestic yet fluid, this table becomes the center of the room thanks to the sophisticated combination of steel cylinders that give it stability and harmony.

## COLORE STRUTTURA STANDARD - STANDARD STRUCTURE COLOR



Bronzo  
Metallizzato



Rame  
Metallizzato



Alluminio  
Goffrato



Avorio  
Opaco



Beige  
Grigio

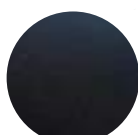

Nero  
Bucciato



Bianco  
Bucciato

## Art. 00-35-01

Base **Ø 55 cm** - 3 cilindri Ø 25 cm  
Struttura in acciaio alta **72 cm** per tavolo fisso  
Colore standard  
Top tavolo escluso

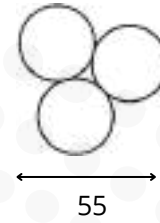

Base **Ø 55 cm** - 3 cylinders Ø 25 cm  
Steel structure **72 cm** high for fixed table  
Standard color  
Table top not included

### Forme e dimensioni top possibili



## Art. 00-35-02

Base **Ø 60 cm** - 4 cilindri Ø 25 cm  
Struttura in acciaio alta **72 cm** per tavolo fisso  
Colore standard  
Top tavolo escluso

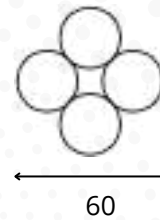

Base **Ø 60 cm** - 4 cylinders Ø 25 cm  
Steel structure **72 cm** high for fixed table  
Standard color  
Table top not included

### Forme e dimensioni top possibili

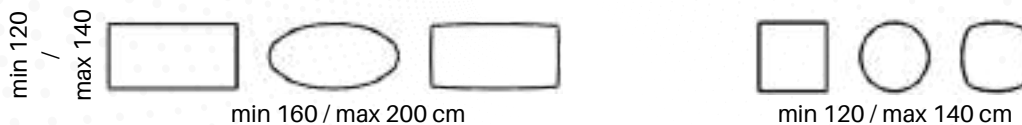

## Art. 00-35-03

Base **Ø 100 cm** - 6 cilindri Ø 25 cm + 1 cilindro Ø 50 cm  
Struttura in acciaio alta **72 cm** per tavolo fisso  
Colore standard  
Top tavolo escluso

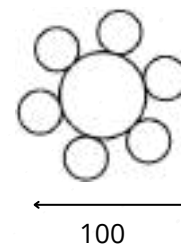

Base **Ø 100 cm** - 6 cylinders Ø 25 cm + 1 cylinder Ø 50 cm  
Steel structure **72 cm** high for fixed table  
Standard color  
Table top not included

### Forme e dimensioni top possibili

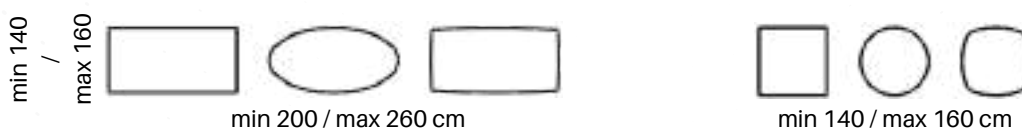

FINITURE TOP TAVOLO PAG. 133 - PREZZI TOP TAVOLO PAG. 153  
TABLE TOP FINISHES PAG. 133 - TABLE TOP PRICES PAG. 153



## CLOVER



# CLOVER WOOD

Art. 00-36

I cilindri in ferro, rivestiti da listelli in legno naturale o verniciato, sono la base di questo tavolo imponente, che unisce elementi moderni e rustici in modo sorprendente.

The iron cylinders, covered with natural or painted wooden strips, are the base of this imposing table, which combines modern and rustic elements in a surprising way.

COLORE STRUTTURA STANDARD - STANDARD STRUCTURE COLOR



naturale



nero



noce chiaro



noce scuro



rovere

## Art. 00-36-01

---

Base Ø 102.5 cm - 6 cilindri Ø 25 cm + 1 cilindro Ø 50 cm

Struttura in acciaio alta 72 cm per tavolo fisso

Colore standard

Top tavolo escluso

Base Ø 102.5 cm - 6 cylinders Ø 25 + 1 cylinder Ø 50 cm

Steel structure 72 cm high for fixed table

Standard color

Table top not included



102.5

### Forme e dimensioni top possibili

min 140  
/  
max 160



min 200 / max 260 cm



min 140 / max 160 cm



Nucleo

FINITURE TOP TAVOLO PAG. 133 - PREZZI TOP TAVOLO PAG. 153

TABLE TOP FINISHES PAG. 133 - TABLE TOP PRICES PAG. 153



## CLOVER WOOD



# STEM

Art. 00-37

Una singola base in ferro e legno cattura lo sguardo su questo tavolo senza tempo che, arricchito dal suo piano, conferisce uno stile shabby chic a qualsiasi spazio.

A single iron and wood base captures the eye on this timeless table which, enriched by its top, gives a shabby chic style to any space.

COLORE STRUTTURA STANDARD - STANDARD STRUCTURE COLOR



naturale

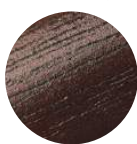

nero



noce chiaro



noce scuro



rovere

## Art. 00-37-01

Base  $\varnothing$  53 cm

Zoccolo in acciaio h.5 cm finitura 24k o ral Standard

Struttura in acciaio alta **72 cm** rivestita con listelli di legno per tavolo fisso

Colore standard

Top tavolo escluso

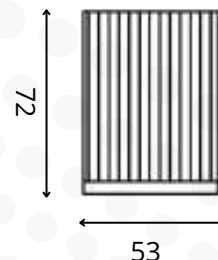

Base  $\varnothing$  53 cm

Steel plinth h.5 cm 24k or RAL Standard finish

Steel structure **72 cm** high covered with wooden strips for fixed table

Standard color

Table top not included

### Forme e dimensioni top possibili



## Art. 00-37-02

Due basi  $\varnothing$  53 cm

Zoccolo in acciaio h.5 cm finitura 24k o ral Standard

Struttura in acciaio alta **72 cm** rivestita con listelli di legno

Per tavolo fisso

Colore standard

Top tavolo escluso

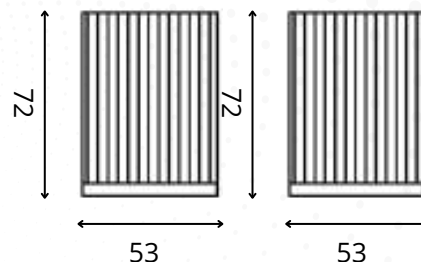

Two bases  $\varnothing$  53 cm

Steel plinth h.5 cm 24k or RAL Standard finish

Steel structure **72 cm** high covered with wooden strips

For fixed table

Standard color

Table top not included

### Forme e dimensioni top possibili

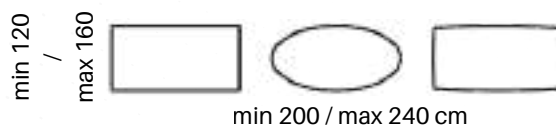

FINITURE TOP TAVOLO PAG. 133 - PREZZI TOP TAVOLO PAG. 153  
TABLE TOP FINISHES PAG. 133 - TABLE TOP PRICES PAG. 153



## STEM



# ROOT

Art. 00-38

Questo tavolo imponente e magnifico conferisce al tuo ambiente uno stile ed eleganza unici, grazie alla sua struttura in acciaio rivestita da listelli in legno fissati uno per uno che esalta la perfezione artigiana del made in Italy.

This imposing and magnificent table gives your environment a unique style and elegance, thanks to its steel structure covered with wooden slats fixed one by one that enhances the artisan perfection of Made in Italy.

COLORE STRUTTURA STANDARD - STANDARD STRUCTURE COLOR



naturale

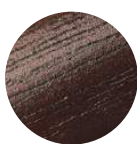

nero



noce chiaro



noce scuro



rovere

## Art. 00-38-01

---

Base **101.5x45.5 cm**

Struttura in acciaio alta **73 cm** rivestita con listelli di legno

Per tavolo fisso

Colore standard

Top tavolo escluso

Base **101.5x45.5 cm**

Steel structure **73 cm** high covered with wooden slats

For fixed table

Standard color

Table top not included

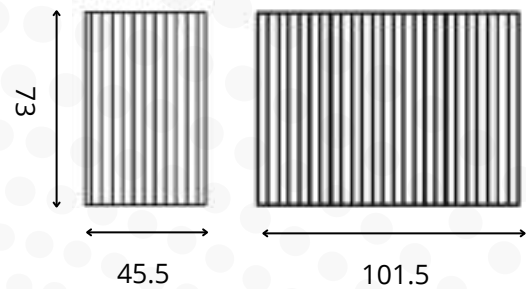

### Forme e dimensioni top possibili



## Art. 00-38-02

---

Base **151.5x45.5 cm**

Struttura in acciaio alta **73 cm** rivestita con listelli di legno

Per tavolo fisso

Colore standard

Top tavolo escluso

Base **151.5x45.5 cm**

Steel structure **73 cm** high covered with wooden slats

For fixed table

Standard color

Table top not included

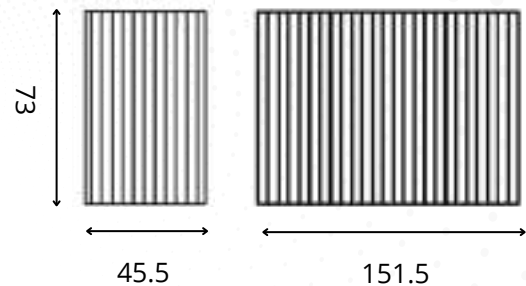

### Forme e dimensioni top possibili



FINITURE TOP TAVOLO PAG. 133 - PREZZI TOP TAVOLO PAG. 153  
TABLE TOP FINISHES PAG. 133 - TABLE TOP PRICES PAG. 153



## ROOT



# SQUARE

Art. 00-40

Questo tavolo solido e squadrato rappresenta una perfetta combinazione di robustezza, leggerezza ed eleganza. La sua struttura geometrica e lineare offre una sensazione di stabilità e resistenza, adattandosi facilmente a diversi stili di arredamento.

This solid and square table represents a perfect combination of strength, lightness and elegance. Its geometric and linear structure offers a feeling of stability and resistance, it easily adapts to different styles of furniture.

## COLORE STRUTTURA STANDARD - STANDARD STRUCTURE COLOR



Bronzo  
Metallizzato



Rame  
Metallizzato



Alluminio  
Goffrato



Avorio  
Opaco



Beige  
Grigio

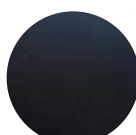

Nero  
Bucciato



Bianco  
Bucciato

## Art. 00-40-01

Base **160X70 cm** - piede 10x2 cm  
Struttura in acciaio alta **72 cm** per tavolo fisso  
Colore standard  
Top tavolo escluso

Base **160X70 cm** - foot 10x2 cm  
Steel structure **72 cm** high for fixed table  
Standard color  
Table top not included

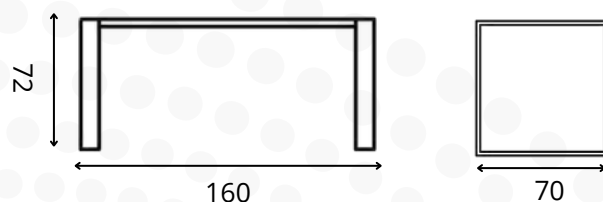

### Forme e dimensioni top possibili

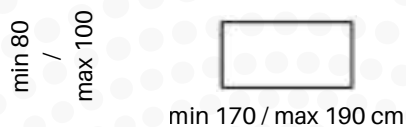

## Art. 00-40-02

Base **180X90 cm** - piede 10x2 cm  
Struttura in acciaio alta **72 cm** per tavolo fisso  
Colore standard  
Top tavolo escluso

Base **180X90 cm** - foot 10x2 cm  
Steel structure **72 cm** high for fixed table  
Standard color  
Table top not included

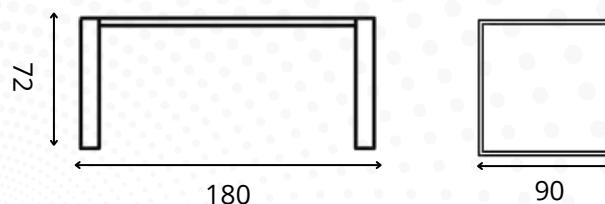

### Forme e dimensioni top possibili



## Art. 00-40-03

Base **200X90 cm** - piede 10x2 cm  
Struttura in acciaio alta **72 cm** per tavolo fisso  
Colore standard  
Top tavolo escluso

Base **200X90 cm** - foot 10x2 cm  
Steel structure **72 cm** high for fixed table  
Standard color  
Table top not included

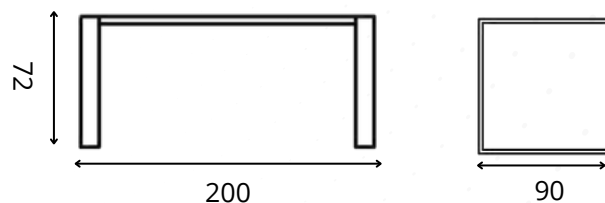

### Forme e dimensioni top possibili

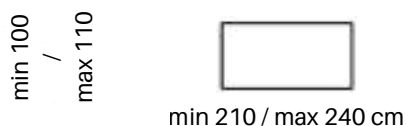

FINITURE TOP TAVOLO PAG. 133 - PREZZI TOP TAVOLO PAG. 153  
TABLE TOP FINISHES PAG. 133 - TABLE TOP PRICES PAG. 153



SQUARE



Nucleo

# Tavoli Allungabili

## Extendable Tables

2025

---



# SUMMER

Art. 40-00

Le quattro gambe che si uniscono al centro e poi si allargano rappresentano l'essenza estetica di questo tavolo. Grazie al suo meccanismo rotante che lo rende allungabile, si adatta perfettamente a qualsiasi arredamento, sia interno che esterno, classico o moderno. Puoi scegliere di abbinarlo a uno dei numerosi colori dei piani in gres che produciamo. Le sue dimensioni fisse e allungabili sono perfette per soddisfare le esigenze degli ambienti familiari.

The four legs that meet in the center and then spread out represent the aesthetic essence of this table. Thanks to its rotating mechanism that allows it to be extended, it fits perfectly with any decor, both indoors and outdoors, classic or modern. You can choose to match it with one of the many colors of the stoneware tops we produce. Its fixed and extendable dimensions are perfect for meeting the needs of family spaces.

## Art. 40-00-01

---

- Telaio in acciaio verniciato a polvere
- Finitura: verniciato nero
- Movimento sincronizzato rotante
- Dimensioni tavolo chiuso: 120x90xh.75 cm
- Dimensioni tavolo aperto: 180x90xh.75 cm
- Top tavolo escluso
- Top tavolo realizzabile sono in ceramica 1,2 cm
- Powder-coated steel frame
- Finish: Black painted
- Rotating synchronized movement
- Closed table dimensions: 120x90xh.75 cm
- Open table dimensions: 180x90xh.75 cm
- Table top not included
- The table top can be made of 1,2 cm ceramic



FINITURE TOP TAVOLO PAG. 140-142 - PREZZI TOP TAVOLO PAG. 153  
TABLE TOP FINISHES PAG. 140-142 - TABLE TOP PRICES PAG. 153



# FALCON

Art. 50-00

Agendo agevolmente sulla leva si attiva il meccanismo rotante utile ad allungare il tavolo , mantenendo fisse al centro le quattro gambe inclinate e separate tra loro che offrono un design semplice ed efficace

Gambe colore nero opaco per abbinarlo a tutte le tipologie di piani in gres di nostra produzione  
Due alternative di misure fisse ed a allungabili soddisfano il ritrovo anche di grandi compagnie

Easily operating the lever activates the rotating mechanism that extends the table, keeping the four tilted and separated legs fixed in the center, offering a simple and effective design.

Matte black legs to match all types of stoneware tops we produce.

Two alternatives, fixed and extendable, satisfy the needs of even large gatherings.

## Art. 50-00-01

---

- Telaio in acciaio verniciato a polvere
- Finitura: verniciato nero
- Movimento sincronizzato rotante
- Dimensioni tavolo chiuso: 120x90xh.75 cm
- Dimensioni tavolo aperto: 180x90xh.75 cm
- Top tavolo escluso
- Top tavolo realizzabile sono in ceramica 1,2 cm
- Powder-coated steel frame
- Finish: Black painted
- Rotating synchronized movement
- Closed table dimensions: 120x90xh.75 cm
- Open table dimensions: 180x90xh.75 cm
- Table top not included
- The table top can be made of 1,2 cm ceramic

## Art. 50-00-02

---

- Telaio in acciaio verniciato a polvere
- Finitura: verniciato nero
- Movimento sincronizzato rotante
- Dimensioni tavolo chiuso: 160x90xh.75 cm
- Dimensioni tavolo aperto: 240x90xh.75 cm
- Top tavolo escluso
- Top tavolo realizzabile sono in ceramica 1,2 cm
- Powder-coated steel frame
- Finish: Black painted
- Rotating synchronized movement
- Closed table dimensions: 160x90xh.75 cm
- Open table dimensions: 240x90xh.75 cm
- Table top not included
- The table top can be made of 1,2 cm ceramic



FINITURE TOP TAVOLO PAG. 140-142 - PREZZI TOP TAVOLO PAG. 153  
TABLE TOP FINISHES PAG. 140-142 - TABLE TOP PRICES PAG. 153



# SPRING

Art. 51-00

Quattro gambe intrecciate conferiscono a questo tavolo un aspetto simile a molti altri, ma un'attenta osservazione rivela che la loro diversa larghezza e inclinazione lo rendono davvero unico.

Il sistema di allunghe esterne e indipendenti consente di trasformare il piano in tre misure diverse: da fisso per spazi medio-piccoli fino all'allungo massimo per ambienti più ampi.

Four intertwined legs give this table a look similar to many others, but upon closer inspection, their varying widths and angles make it truly unique.

The independent, external extension system allows the tabletop to be extended to three different sizes: from fixed for small to medium-sized spaces to fully extendable for larger spaces.

## Art. 51-00-01

---

- Telaio in acciaio verniciato a polvere
- Finitura: verniciato nero
- Due allunghe laterali
- Dimensioni tavolo chiuso: 160x90xh.75 cm
- Dimensioni tavolo aperto: 240x90xh.75 cm
- Top tavolo escluso
- Top tavolo realizzabile sono in ceramica 1,2 cm
- Powder-coated steel frame
- Finish: Black painted
- Two side extensions
- Closed table dimensions: 160x90xh.75 cm
- Open table dimensions: 240x90xh.75 cm
- Table top not included
- The table top can be made of 1,2 cm ceramic



FINITURE TOP TAVOLO PAG. 140-142 - PREZZI TOP TAVOLO PAG. 153  
TABLE TOP FINISHES PAG. 140-142 - TABLE TOP PRICES PAG. 153



# EAGLE

Art. 52-00

In questo tavolo si racchiude la bellezza della semplicità e l'efficienza del design, con il nostro piano in gres che sembra fluttuare sopra il telaio.

Le quattro gambe, di cui solo due si allungano, creano un affascinante gioco di spazi vuoti e solidi. Sia la misura fissa che quella allungata si adattano perfettamente a qualsiasi ambiente di medie dimensioni.

This table embodies the beauty of simplicity and efficient design, with our stoneware top seemingly floating above the frame.

The four legs, only two of which extend, create a fascinating interplay of empty and solid spaces.

Both the fixed and extended versions are perfect for any medium-sized space.

## Art. 52-00-01

---

- Telaio in acciaio verniciato a polvere
- Finitura: verniciato nero
- Meccanismo scorrevole
- Dimensioni tavolo chiuso: 140x90xh.75 cm
- Dimensioni tavolo aperto: 200x90xh.75 cm
- Top tavolo escluso
- Top tavolo realizzabile sono in ceramica 1,2 cm
- Powder-coated steel frame
- Finish: Black painted
- Sliding mechanism
- Closed table dimensions: 140x90xh.75 cm
- Open table dimensions: 200x90xh.75 cm
- Table top not included
- The table top can be made of 1,2 cm ceramic



FINITURE TOP TAVOLO PAG. 140-142 - PREZZI TOP TAVOLO PAG. 153  
TABLE TOP FINISHES PAG. 140-142 - TABLE TOP PRICES PAG. 153





# Consolle

## Consolle

2025

---



# MADRID

Art. 100-01

La madia MADRID, con le sue linee squadrate e geometriche, incarna l'essenzialità e la semplicità. La vasta gamma di finiture in legno o laccato o ceramica, arricchita da eleganti ripiani, ci consente di realizzare abbinamenti sia eccentrici che classici, adattandosi perfettamente alla nostra visione di ambiente.

The MADRID sideboard, with its square, geometric lines, embodies essentiality and simplicity. The wide range of finishes—wood, lacquer, or ceramic—enhanced with elegant shelves allows for both eccentric and classic combinations, perfectly adapting to your space's vision.



MADRID

# FINITURE IN LEGNO MASSELLO MASSELLO WOOD FINISHES

Per basi mobili For furniture bases



Castagno Naturale Levigato



Castagno Levigato Saponato



Castagno Ossidato Grigio Levigato



Castagno Moro Levigato



Castagno Vecchio non Levigato

# COLORI LACCATI LUCIDI - OPACHI COLOUR MATT LACQUARED

Per basi mobili For mobile bases

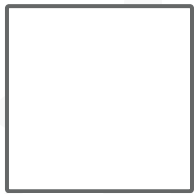

Bianco

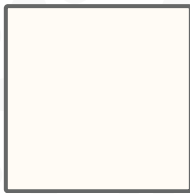

Panna



Crema



Caffè Latte



Beige Cipria



Giallo Canarino

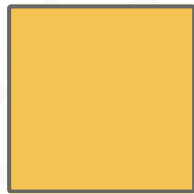

Giallo Senape



Beige Perlato



Canapa



Marrone

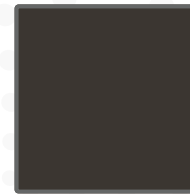

Grigio Fumo

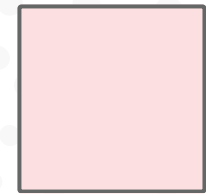

Rosa Chiaro

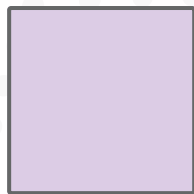

Lilla



Fucsia Perlato



Prugna



Fucsia

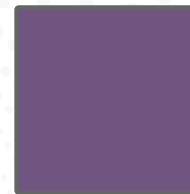

Lavanda



Melanzana

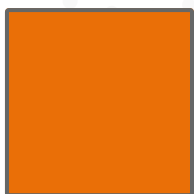

Arancio



Rosso Rubino



Rosso Porpora



Grigio Luce



Grigio Medio

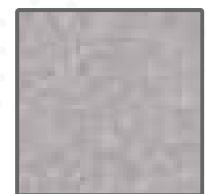

Grigio Metal



Grigio Antracite

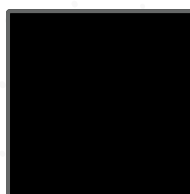

Nero



Azzurro Limpido



Azzurro Cielo



Blu Colomba



Blu Oceano

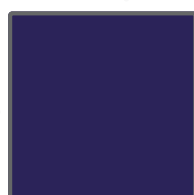

Blu Notte



Verde Cristallo



Verde Turchese



Verde Salvia

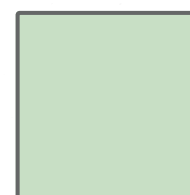

Verde Acqua



Verde Mela

# FINITURE ANTE IN GRES 6 MM

## GRES 6 MM DOOR FINISHES

Per basi mobili For furniture bases

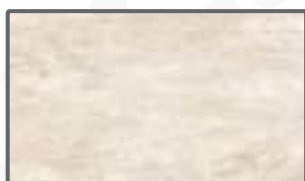

Ardesia Bianco



Ardesia Ecrú'



Ardesia Grigia



Ardesia Nera



Calacatta Oro O.



Corten



Grafite

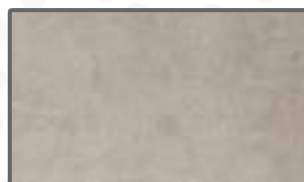

Limestone Ash



Limestone Deep



Limestone Moon



Spatolato Amber

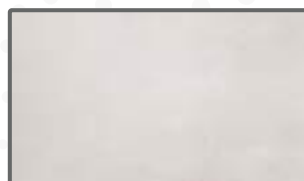

Spatolato Ivory

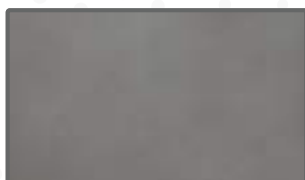

Spatolato Plumb

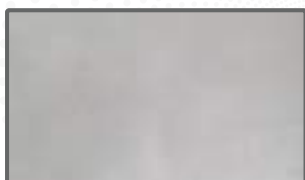

Spatolato Silver



Statuario



Travertino Gold



Verde Alpi



Azzurro



Calacatta Bianco



Calacatta Oro L.



Emperador (C6)



Gaudi (C6)



Nero Marquinia



Nero Portoro



Onice Noisette



Port Laurent



Travertino

**BASI PROFONDITA' 50 CM - sistema di apertura PUSH-PULL**  
**BASES DEPTH 46 CM - opening system PUSH-PULL**

**Base 2 cassetti H.50 cm**  
 base 2 drawers H.50 cm



LARGHEZZA (CM) WIDHT (CM)	CODICE CODE	LACCATO OPACO MATT LACQUERED	LACCATO LUCIDO GLOSSY LACQUERED	LEGNO CASTAGNO CHESTNUT WOOD	GRES GRES
25	LGLF10				
35	LGLF11				
50	LGLF12				
70	LGLF13				
85	LGLF14				
100	LGLF15				
120	LGLF16				

*finiture riferite solo alla parte frontale delle basi.*  
*finishes referring only to the front part of the bases.*

**Base contenitore 1 anta H.50 cm**  
 1 door container base H.50 cm

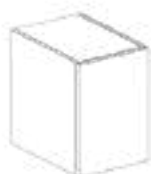

LARGHEZZA (CM) WIDHT (CM)	CODICE CODE	LACCATO OPACO MATT LACQUERED	LACCATO LUCIDO GLOSSY LACQUERED	LEGNO CASTAGNO CHESTNUT WOOD	GRES GRES
25	LGLF30				
35	LGLF31				

*finiture riferite solo alla parte frontale delle basi.*  
*finishes referring only to the front part of the bases.*

**Base contenitore 2 ante H.50 cm**  
 2 doors container base H.50 cm



LARGHEZZA (CM) WIDHT (CM)	CODICE CODE	LACCATO OPACO MATT LACQUERED	LACCATO LUCIDO GLOSSY LACQUERED	LEGNO CASTAGNO CHESTNUT WOOD	GRES GRES
50	LGLF40				
70	LGLF41				

*finiture riferite solo alla parte frontale delle basi.*  
*finishes referring only to the front part of the bases.*

**FIANCHI DI FINITURA P.50**  
**FINISHING SIDES P.50**

**Fianco di finitura H.50 cm**  
 Finishing side H.50 cm



LARGHEZZA (CM) WIDHT (CM)	CODICE CODE	LACCATO OPACO MATT LACQUERED	LACCATO LUCIDO GLOSSY LACQUERED	LEGNO CASTAGNO CHESTNUT WOOD	GRES GRES
50	LGLFFI				

**ATTENZIONE:** per la composizione del mobile è sempre necessario scegliere e aggiungere i due fianchi di finitura  
**ATTENTION:** to compose the furniture it is always necessary to choose and add the two finishing sides

**PIEDI DI METALLO PER BASI**  
**METAL FEET FOR BASES**

**Piedi di metallo H.12 cm**  
 Metal feet H.12 cm



CODICE CODE	LEGNO MELAMINICO MELAMINIC WOOD
LGLFPI	

## MANIGLIE HANDLESS

Tutti i prezzi della basi sono riferiti con sistema di apertura PUSH-PULL per ante/cassetti.

Si puo' inserire il sistema di apertura a maniglia scegliendo tra i modelli elencati.

**ATTENZIONE:**  
Le maniglie non possono essere applicate sulle ante /cassetti con il rivestimento frontale in gres ad esclusione della maniglia **SEGNO** che va avvitata sul lato interno.

All base unit prices include a PUSH-PULL opening system for doors/drawers.

A handle opening system can be installed by choosing from the models listed.

**PLEASE NOTE:**  
Handles cannot be applied to doors/drawers with a stoneware front, with the exception of the **SEGNO** handle, which must be screwed onto the inside.

### LINE



Maniglia in alluminio  
verniciato a polvere  
Nero Opaco

Aluminum handle  
Powder-coated  
Matte Black

LUNGHEZZA(CM) LENGTH(CM)	CODICE CODE
18	LGLFM50
30	LGLFM51
45	LGLFM52
60	LGLFM53
90	LGLFM54
120	LGLFM55

#### Schema posizionamento maniglie - hanle positioning diagram



L.BASE L.BASE	L.MANIGLIA L.HANDLESS
25	20
35	20/30
50	30/45
70	30/45/60
85	45/60
100	45/60/90
120	60/90/120



L.BASE L.BASE	L.MANIGLIA L.HANDLESS
25	20
35	20/30

### SEGNO



Maniglia in alluminio  
verniciato a polvere  
Nero Opaco

Aluminum handle  
Powder-coated  
Matte Black

LUNGHEZZA(CM) LENGTH(CM)	CODICE CODE
18	LGLFM70
28	LGLFM71
33	LGLFM72
38	LGLFM73
48	LGLFM74
68	LGLFM75

#### Schema posizionamento maniglie - hanle positioning diagram



L.BASE L.BASE	L.MANIGLIA L.HANDLESS
25	18
35	18/28
50	28/33
70	38/48
85	38/48/68
100	48/68
120	48/68



L.BASE L.BASE	L.MANIGLIA L.HANDLESS
25	20
35	20/30

## RULE



Maniglia in metallo pieno  
sp. 5mm verniciata a  
polvere Nero Opaco

Solid metal handle  
5mm thick, powder-coated  
Matte Black

LUNGHEZZA (CM) LENGTH (CM)	CODICE CODE
17	LGLFM80
25	LGLFM81



### Schema posizionamento maniglie - handle positioning diagram

L.BASE L.BASE	L.MANIGLIA L.HANDLESS
25	25/17
35	25/17
50	25/17
70	25/17
85	25/17
100	25/17
120	25/17

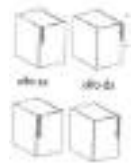

L.BASE L.BASE	L.MANIGLIA L.HANDLESS
25	25/17
35	25/17

## LACE



Maniglia in metallo  
Nero Opaco e cinturino  
in pelle colore  
testa di moro.

LARGHEZZA (CM) WIDHT (CM)	CODICE CODE
18	LGLFM90

Matte black metal handle  
and dark brown leather  
strap.

### Schema posizionamento maniglie - handle positioning diagram

L.BASE L.BASE	L.MANIGLIA L.HANDLESS
25	14
35	14
50	14
70	14
85	14
100	14
120	14



L.BASE L.BASE	L.MANIGLIA L.HANDLESS
25	14
35	14



# PARIGI

Art. 100-02

La madia PARIGI rappresenta l'incontro perfetto tra design e praticità, l'ideale equilibrio tra estetica e funzionalità. Con una base ovale in metallo dalle linee morbide e minimaliste, è impreziosita da un piano in marmo o gres, capace di arricchire e valorizzare qualsiasi ambiente.

Giocando con colori e materiali, è possibile creare una combinazione che si adatta a ogni stile di arredamento e a ogni personalità.

The PARIGI sideboard represents the perfect blend of design and practicality, the ideal balance between aesthetics and functionality. Featuring an oval metal base with soft, minimalist lines, it is embellished with a marble or stoneware top, capable of enriching and enhancing any space.

By playing with colors and materials, you can create a combination that adapts to any furnishing style and personality.



## PARIGI

# FINITURE ACCIAIO STANDARD STANDARD STEEL FINISHES

Per basi mobili For furniture bases



Bronzo Metallizzato



Rame Metallizzato

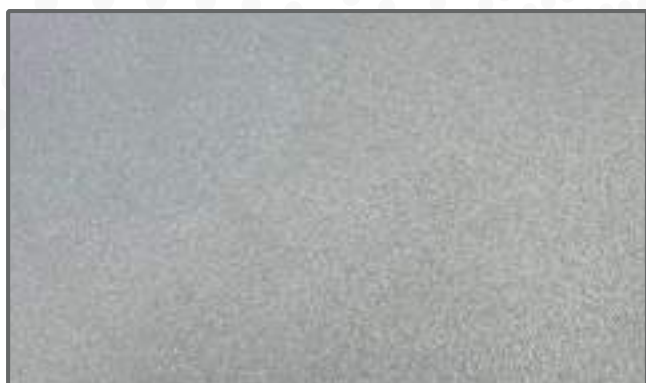

Alluminio Goffrato



Avorio Opaco



Beige Grigio



Nero Bucciato

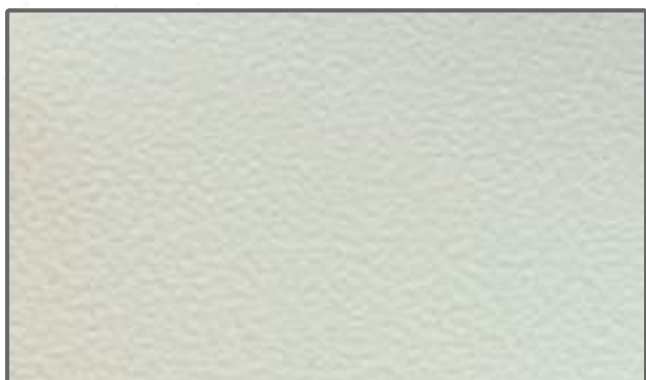

Bianco Bucciato

**MADIA ALTEZZA 73 CM  
SIDEBOARD HEIGHT 73 CM**

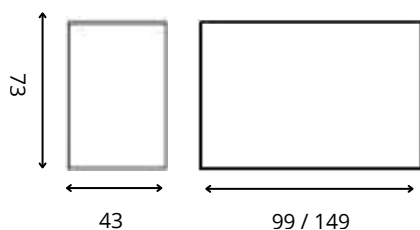

Struttura in acciaio - Colore standard  
Top madia esclusa

Steel structure - Standard color  
sideboard top not included

MISURE (CM) MISURES (CM)	CODICE CODE
99X43	VEIK100
149X43	VEIK101

Forma e dimensione top

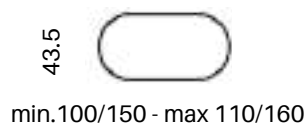

**MADIA ALTEZZA 110 CM  
SIDEBOARD HEIGHT 110 CM**

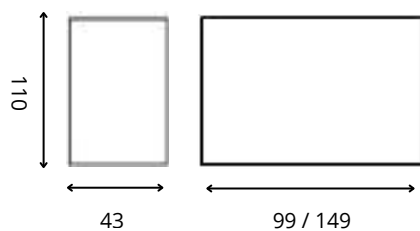

Struttura in acciaio - Colore standard  
Top madia esclusa

Steel structure - Standard color  
sideboard top not included

MISURE (CM) MISURES (CM)	CODICE CODE
99x43	VEIK150
149X43	VEIK151

Forma e dimensione top

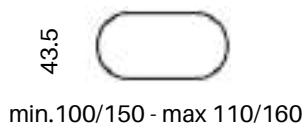



# VIENNA

Art. 100-03

I listelli in legno con diverse finiture conferiscono alla madia VIENNA un calore di eleganza senza tempo, arricchita da ripiani in marmo o gres. Versatile e raffinata, rappresenta un complemento d'arredo ideale sia per ambienti moderni che per quelli dal sapore retrò.

The wooden slats in various finishes give the VIENNA sideboard a warm, timeless elegance, enhanced by marble or stoneware shelves. Versatile and refined, it's an ideal furnishing accessory for both modern and retro-inspired spaces.



## VIENNA

# FINITURE IN LEGNO MASSELLO

## MASSELLO WOOD FINISHES

Per basi mobili For furniture bases

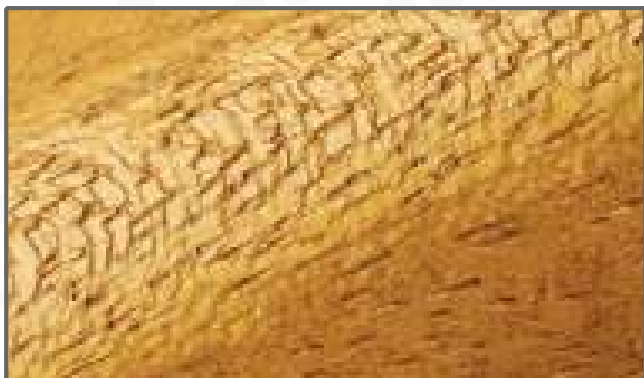

Naturale



Nero

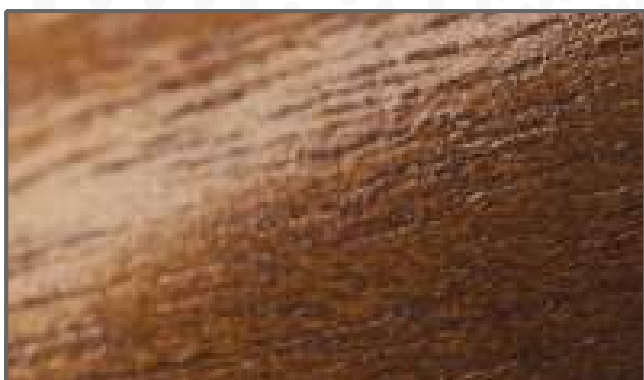

Noce Chiaro



Noce Scuro



Rovere

## MADIA ALTEZZA 73 CM SIDEBOARD HEIGHT 73 CM

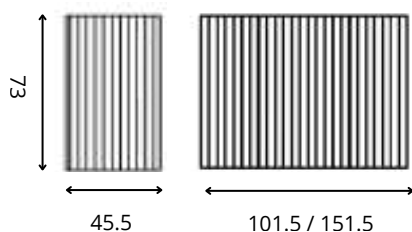

Struttura in acciaio rivestita di listelli  
in legno - Colore standard  
Top madia esclusa

Steel structure covered with  
wooden slats - Standard color  
sideboard top not included

MISURE (CM) MISURES (CM)	CODICE CODE
101.5x45.5	VEIKW50
151.5x45.5	VEIKW51

### Forma e dimensione top

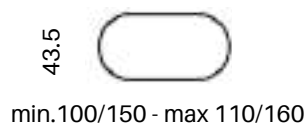

## MADIA ALTEZZA 110 CM SIDEBOARD HEIGHT 110 CM

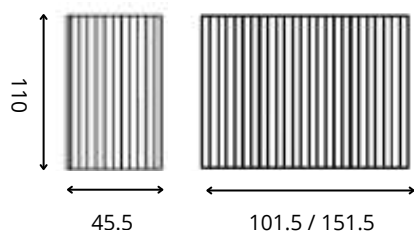

Struttura in acciaio rivestita di listelli  
in legno - Colore standard  
Top madia esclusa

Steel structure covered with  
wooden slats - Standard color  
sideboard top not included

MISURE (CM) MISURES (CM)	CODICE CODE
101.5x45.5	VEIKW70
151.5x45.5	VEIKW71

### Forma e dimensione top

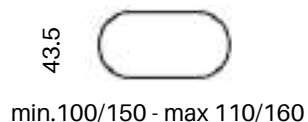



# LONDRA

Art. 100-04

La madia LONDRA, elegante e funzionale, con i suoi listelli in legno e mensole, rappresenta un perfetto connubio tra raffinatezza e praticità. La sua versatilità nelle tonalità delle finiture in legno e nei materiali abbinabili la rende ideale per qualsiasi ambiente della casa.

The elegant and functional LONDRA sideboard, with its wooden slats and shelves, represents the perfect combination of refinement and practicality. Its versatility in wood finishes and matching materials makes it ideal for any room in the home.



LONDRA

# FINITURE IN LEGNO MASSELLO

## MASSELLO WOOD FINISHES

Per basi mobili For furniture bases



Naturale



Nero

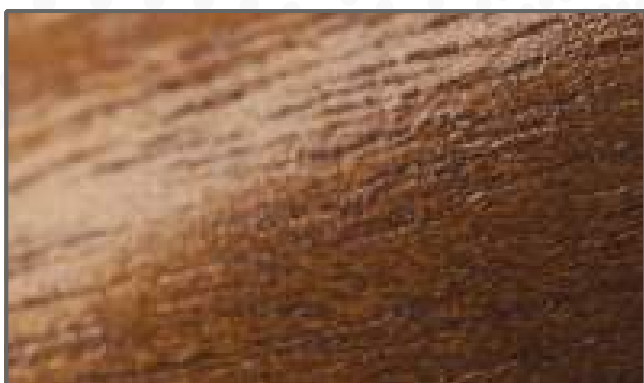

Noce Chiaro



Noce Scuro



Rovere

**MADIA ALTEZZA 110 CM  
SIDEBOARD HEIGHT 110  
CM**

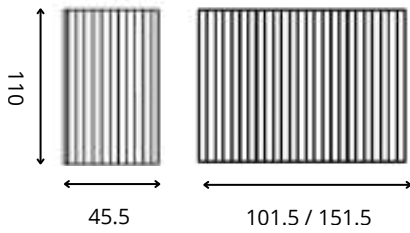

Struttura in acciaio rivestita di listelli  
in legno - con mensole  
Colore standard  
Top madia esclusa

Steel structure covered with  
wooden slats - with shelves  
Standard color  
sideboard top not included

MISURE (CM) MISURES (CM)	CODICE CODE
101.5x45.5	VEIKB200
151.5x45.5	VEIKB201

Forma e dimensione top

43.5



min.100/150 - max 110/160



# BERLINO

Art. 100-05

La consolle BERLINO, caratterizzata da un design semplice ed elegante, rappresenta un perfetto connubio tra raffinatezza e minimalismo. La base in ferro, personalizzabile in diverse tonalità, sostiene un piano in marmo, quarzo o ceramica che ne valorizza lo stile.

The BERLINO console table, featuring a simple and elegant design, represents the perfect blend of sophistication and minimalism. The iron base, customizable in a variety of shades, supports a marble, quartz, or ceramic top that enhances its style.



## BERLINO

# FINITURE ACCIAIO STANDARD STANDARD STEEL FINISHES

Per basi mobili For furniture bases



Bronzo Metallizzato



Rame Metallizzato



Alluminio Goffrato



Avorio Opaco



Beige Grigio



Nero Bucciato

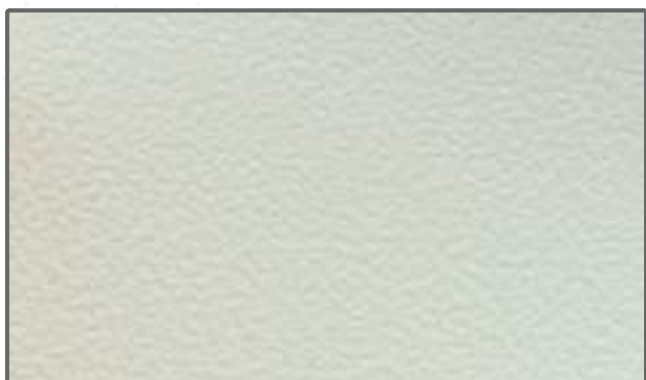

Bianco Bucciato

**MADIA ALTEZZA 87 CM  
SIDEBOARD HEIGHT 87  
CM**

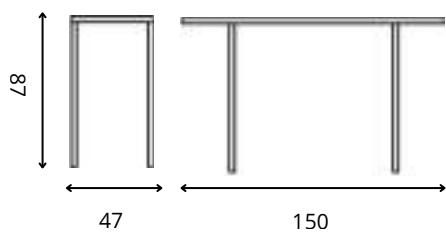

Struttura in acciaio  
Colore standard  
Top madia esclusa

Steel structure  
Standard color  
sideboard top not included

MISURE (CM) MISURES (CM)	CODICE CODE
150x47	LPBAN70

Forma e dimensione top

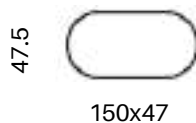

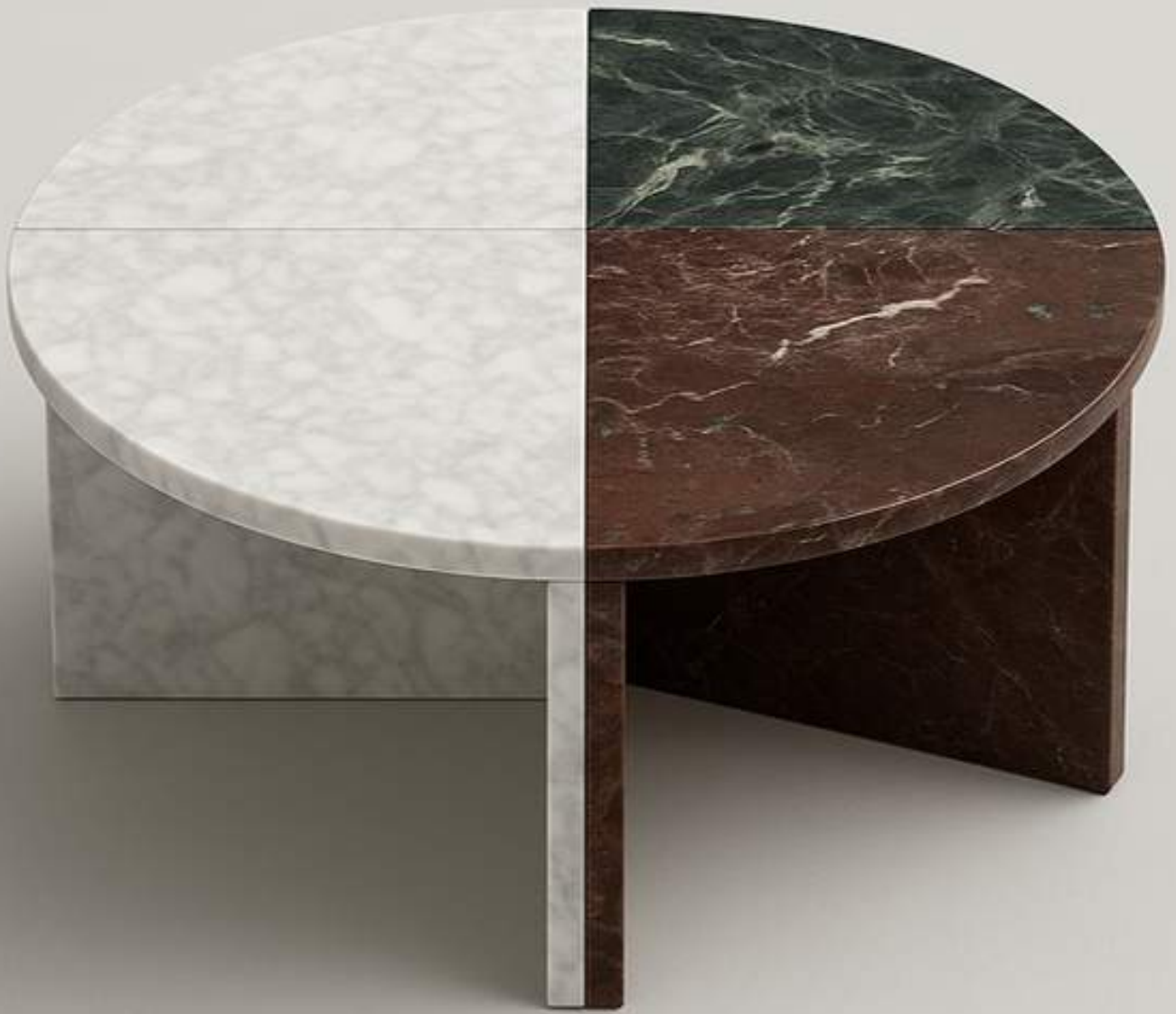



# Tavolini

## Coffee Tables

2025

---



# DAHALLIA\_B

Art. 10-15

Questo tavolino dal design raffinato e linee pulite è un complemento di arredo capace di integrarsi con diversi stili di arredamento.

This coffee table with a refined design and clean lines is a furnishing accessory capable of integrating with different furnishing styles.

## COLORE STRUTTURA STANDARD - STANDARD STRUCTURE COLOR



Bronzo  
Metallizzato



Rame  
Metallizzato



Alluminio  
Goffrato



Avorio  
Opaco



Beige  
Grigio

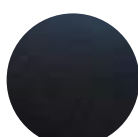

Nero  
Bucciato



Bianco  
Bucciato

## Art. 10-15-01

Base  $\varnothing$  45 cm con massima apertura  $\varnothing$  62 cm

Struttura in acciaio alta 40 cm

Colore standard

Top tavolo escluso

Base  $\varnothing$  45 cm with maximum opening  $\varnothing$  62 cm

Steel structure 40 cm high

Standard color

Table top not included

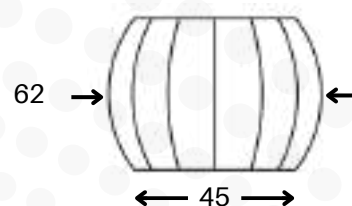

Forme e dimensioni top possibili



min 65 / max 120 cm



FINITURE TOP TAVOLO PAG. 133 - PREZZI TOP TAVOLO PAG. 153

TABLE TOP FINISHES PAG. 133 - TABLE TOP PRICES PAG. 153



# CALLA\_B

Art. 10-20

Con la sua struttura ad archi, questo tavolino racchiude una bellezza semplice che cattura immediatamente l'attenzione. Un esempio perfetto di come la semplicità possa essere sinonimo di sofisticatezza.

With its arched structure, this coffee table has a simple beauty that immediately catches the eye. A perfect example of how simplicity can be synonymous with sophistication.

## COLORE STRUTTURA STANDARD - STANDARD STRUCTURE COLOR



Bronzo  
Metallizzato



Rame  
Metallizzato



Alluminio  
Goffrato



Avorio  
Opaco



Beige  
Grigio

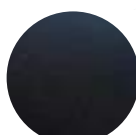

Nero  
Bucciato



Bianco  
Bucciato

## Art. 10-20-01

Base Ø 45 cm con minima apertura Ø 22.5 cm

Struttura in acciaio alta 40 cm

Colore standard

Top tavolo escluso

Base Ø 45 cm with minimum opening Ø 22.5 cm

Steel structure 40 cm high

Standard color

Table top not included

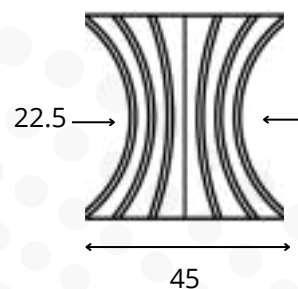

Forme e dimensioni top possibili



min 50 / max 90 cm



FINITURE TOP TAVOLO PAG. 133 - PREZZI TOP TAVOLO PAG. 153

TABLE TOP FINISHES PAG. 133 - TABLE TOP PRICES PAG. 153



# IRIS\_B

Art. 10-30

Un tavolino con un'unica base conica rappresenta una perfetta sintesi tra semplicità senza tempo e innovazione moderna. La forma conica, elegante e minimalista, non solo offre stabilità strutturale ma diventa anche un elemento di design distintivo che cattura l'attenzione senza risultare eccessivo.

A coffee table with a single conical base represents a perfect synthesis between timeless simplicity and modern innovation. The elegant and minimalist conical shape not only offers structural stability but also becomes a distinctive design element that captures attention without being excessive.

## COLORE STRUTTURA STANDARD - STANDARD STRUCTURE COLOR



Bronzo  
Metallizzato

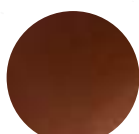

Rame  
Metallizzato



Alluminio  
Goffrato



Avorio  
Opaco



Beige  
Grigio

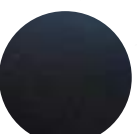

Nero  
Bucciato



Bianco  
Bucciato

## Art. 10-30-01

Base  $\varnothing$  31 cm con minima apertura  $\varnothing$  15 cm  
Struttura in acciaio alta 45 cm  
Colore standard  
Top tavolo escluso

Base  $\varnothing$  31 cm with minimum opening  $\varnothing$  15 cm  
Steel structure 45 cm high  
Standard color  
Table top not included

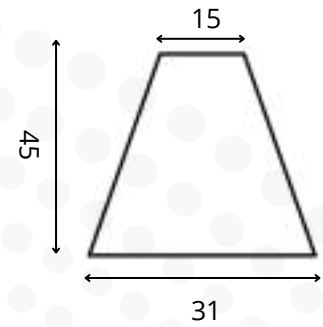

### Forme e dimensioni top possibili



min 50 / max 80 cm



FINITURE TOP TAVOLO PAG. 133 - PREZZI TOP TAVOLO PAG. 153  
TABLE TOP FINISHES PAG. 133 - TABLE TOP PRICES PAG. 153



# STEM\_B

Art. 10-36

Un unico cilindro di legno può diventare un elemento centrale perfetto per ottenere uno stile shabby chic che sia al contempo elegante e rustico, mentre la semplicità della forma cilindrica gli dona un senso di armonia.

A single wooden cylinder can become a perfect central element to achieve a shabby chic style that is both elegant and rustic, while the simplicity of the cylindrical shape gives it a sense of harmony.

## COLORE STRUTTURA STANDARD - STANDARD STRUCTURE COLOR



Bronzo  
Metallizzato



Rame  
Metallizzato



Alluminio  
Goffrato



Avorio  
Opaco



Beige  
Grigio

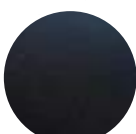

Nero  
Bucciato



Bianco  
Bucciato

## Art. 10-36-01

Base Ø 50 cm  
Struttura in ferro alta 45 cm rivestita con listelli di legno  
Colore standard  
Top tavolo escluso

Base Ø 50 cm  
Iron structure 45 cm high covered with wooden slats  
Standard color  
Table top not included

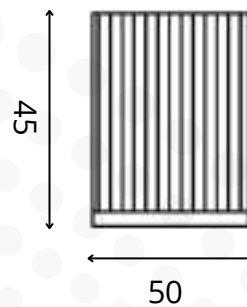

Forme e dimensioni top possibili



min 50 / max 100 cm



FINITURE TOP TAVOLO PAG. 133 - PREZZI TOP TAVOLO PAG. 153  
TABLE TOP FINISHES PAG. 133 - TABLE TOP PRICES PAG. 153



# VIOLET

Art. 10-52

Questo tavolino rappresenta un complemento di arredo versatile e di classe per chi cerca stabilità senza rinunciare al design raffinato. La sua struttura incrociata dei piedi non solo garantisce una solida base, ma aggiunge anche un tocco di sofisticatezza all'arredamento.

This coffee table is a versatile and classy piece of furniture for those seeking stability without sacrificing refined design. Its crossed structure of the feet not only ensures a solid base, but also adds a touch of sophistication to the decor.

## COLORE STRUTTURA STANDARD - STANDARD STRUCTURE COLOR



Bronzo  
Metallizzato



Rame  
Metallizzato



Alluminio  
Goffrato



Avorio  
Opaco



Beige  
Grigio



Nero  
Bucciato



Bianco  
Bucciato

## Art. 10-52-01

Base **60x60 cm**  
Struttura in ferro alta **45 cm**  
Colore standard  
Top tavolo escluso

Base **60x60 cm**  
Iron structure **45 cm** high  
Standard color  
Table top not included

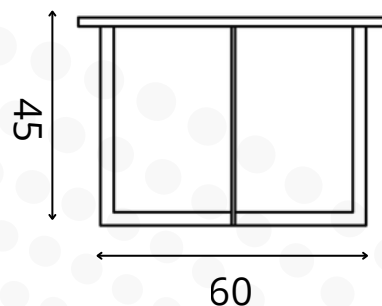

Forme e dimensioni top possibili



min 65 / max 80 cm



FINITURE TOP TAVOLO PAG. 133 - PREZZI TOP TAVOLO PAG. 153  
TABLE TOP FINISHES PAG. 133 - TABLE TOP PRICES PAG. 153



# ROSE

Art. 10-50

Questo tipo di tavolino dalla forma circolare permette di creare un punto focale armonioso e fluido all'interno di qualsiasi ambiente, facilitando la conversazione e la convivialità. Versatile e raffinato è capace di arricchire qualsiasi spazio con un tocco di eleganza discreta.

This type of circular coffee table allows you to create a harmonious and fluid focal point within any environment, facilitating conversation and conviviality. Versatile and refined, it is capable of enriching any space with a touch of discreet elegance.

## COLORE STRUTTURA STANDARD - STANDARD STRUCTURE COLOR



Bronzo  
Metallizzato

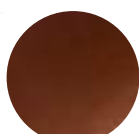

Rame  
Metallizzato



Alluminio  
Goffrato



Avorio  
Opaco



Beige  
Grigio

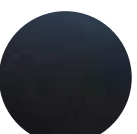

Nero  
Bucciato



Bianco  
Bucciato

## Art. 10-50-01

---

Base **Ø 50 cm**

Struttura in acciaio alta **40 cm** per tavolo fisso

Colore standard

Top tavolo escluso

---

Base **Ø 50 cm**

Steel structure **40 cm** high steel structure for fixed table

Standard color

Table top not included

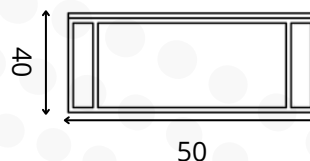

Forme e dimensioni top possibili



50 cm

## Art. 10-50-02

---

Base **Ø 80 cm**

Struttura in acciaio alta **40 cm** per tavolo fisso

Colore standard

Top tavolo escluso

---

Base **Ø 80 cm**

Steel structure **40 cm** high steel structure for fixed table

Standard color

Table top not included

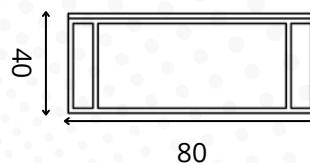

Forme e dimensioni top possibili



80 cm

## Art. 10-50-03

---

Base **Ø 100 cm**

Struttura in acciaio alta **40 cm** per tavolo fisso

Colore standard

Top tavolo escluso

---

Base **Ø 100 cm**

Steel structure **40 cm** high steel structure for fixed table

Standard color

Table top not included

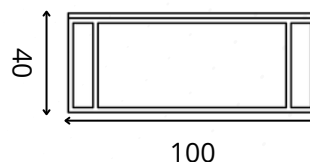

Forme e dimensioni top possibili



100 cm



ROSE



# LEAF

Art. 10-51

Questo complemento di arredo con doppio appoggio, è versatile e funzionale, combinando discrezione e modernità in un unico design. Le linee pulite e minimaliste si integrano perfettamente in un contesto contemporaneo, assicurando una presenza discreta ed elegante.

This piece of furniture with double support is versatile and functional, combining discretion and modernity in a single design. The clean and minimalist lines integrate perfectly into a contemporary context, ensuring a discreet and elegant presence.

## COLORE STRUTTURA STANDARD - STANDARD STRUCTURE COLOR



Bronzo  
Metallizzato



Rame  
Metallizzato



Alluminio  
Goffrato



Avorio  
Opaco



Beige  
Grigio



Nero  
Bucciato



Bianco  
Bucciato

## Art. 10-51-01

---

### Base 60X60 cm

Struttura in acciaio alta **40 cm** con cornice h. 3 cm  
Colore standard  
Top tavolo escluso

---

### Base 60X60 cm

Steel structure **40 cm** high with frame h. 3 cm  
Standard color  
Table top not included

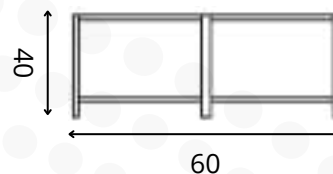

Forme e dimensioni top possibili



## Art. 10-51-02

---

### Base 80X80 cm

Struttura in acciaio alta **40 cm** con cornice h. 3 cm  
Colore standard  
Top tavolo escluso

---

### Base 80X80 cm

Steel structure **40 cm** high with frame h. 3 cm  
Standard color  
Table top not included

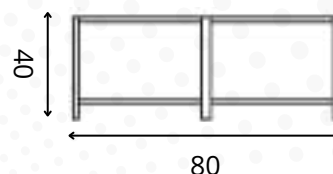

Forme e dimensioni top possibili



## Art. 10-51-03

---

### Base 100X100 cm

Struttura in acciaio alta **40 cm** con cornice h. 3 cm  
Colore standard  
Top tavolo escluso

---

### Base 100x100 cm

Steel structure **40 cm** high with frame h. 3 cm  
Standard color  
Table top not included

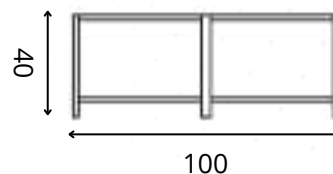

Forme e dimensioni top possibili

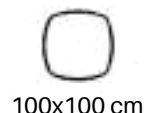



# LEAF



# STONE

Art. 10-60

Questo tavolino di solo marmo è unico nel suo genere perché unisce la ricercatezza del materiale con l'eleganza delle linee. Rifinito con cura artigianale, questo complemento di arredo rappresenta una perfetta fusione tra tradizione e modernità, non solo è funzionale, ma anche un'opera d'arte che cattura l'attenzione e arricchisce lo spazio.

This marble-only coffee table is one of a kind because it combines the refinement of the material with the elegance of the lines. Finished with artisanal care, this piece of furniture represents a perfect fusion between tradition and modernity, not only is it functional, but also a work of art that captures attention and enriches the space.

## Art. 10-60-01

Tavolo **Ø 50 cm** - altezza **50 cm** per tavolo fisso  
Colore marmo naturale categorie M1-M2-M3-M4 o Agglomerato Terrazzo T1

-----  
Table **Ø 50 cm** - height **50 cm** for fixed table  
Marbre color categoris M1-M2-M3-M4 or Agglomerate Terrazzo T1

Struttura e piano in marmo naturale M1  
Structure and top in natural marble M1

Struttura e piano in marmo naturale M2 o T1  
Structure and top in natural marble M2 or T1

Struttura e piano in marmo naturale M3  
Structure and top in natural marble M3

Struttura e piano in marmo naturale M4  
Structure and top in natural marble M4

## Art. 10-60-02

Tavolo **Ø 80/90 cm** - altezza **40 cm** per tavolo fisso  
Colore marmo naturale categorie M1-M2-M3-M4 o Agglomerato Terrazzo T1

-----  
Table **Ø 80/90 cm** - height **40 cm** for fixed table  
Marbre color categoris M1-M2-M3-M4 or Agglomerate Terrazzo T1

Struttura e piano in marmo naturale M1  
Structure and top in natural marble M1

Struttura e piano in marmo naturale M2 o T1  
Structure and top in natural marble M2 or T1

Struttura e piano in marmo naturale M3  
Structure and top in natural marble M3

Struttura e piano in marmo naturale M4  
Structure and top in natural marble M4

## Art. 10-60-03

Tavolo **95x60 cm / 105x65 cm** - altezza **40 cm** per tavolo fisso  
Colore marmo naturale categorie M1-M2-M3-M4 o Agglomerato Terrazzo T1

-----  
Table **95x60 cm / 105x65 cm** - height **40 cm** for fixed table  
Marbre color categoris M1-M2-M3-M4 or Agglomerate Terrazzo T1

Struttura e piano in marmo naturale M1  
Structure and top in natural marble M1

Struttura e piano in marmo naturale M2 o T1  
Structure and top in natural marble M2 or T1

Struttura e piano in marmo naturale M3  
Structure and top in natural marble M3

Struttura e piano in marmo naturale M4  
Structure and top in natural marble M4



## STONE



# CUBE

Art. 10-65

Questo tavolino, completamente realizzato in ceramica, rappresenta un esempio impeccabile di design raffinato e artigianale. Il suo stile cattura immediatamente l'attenzione, combinando una presenza importante con un'eleganza sobria e sofisticata. Ogni dettaglio è studiato per conferire al tavolino una bellezza che unisce arte e praticità.

This coffee table, made entirely of ceramic, is an impeccable example of refined and artisanal design. Its style immediately captures attention, combining an important presence with a sober and sophisticated elegance. Every detail is designed to give the coffee table a beauty that combines art and practicality.

## Art. 10-65-01

Tavolo **30x30 cm / 50x50 cm** - altezza **60 cm** per tavolo fisso  
Colore ceramica categorie C1-C2-C3

---

Table **30x30 cm / 50x50 cm** - height **60 cm** for fixed table  
Ceramic color categoris C1-C2-C3

Struttura e piano in ceramica C1  
Structure and top in ceramic C1

Struttura e piano in ceramica C2  
Structure and top in ceramic C2

Struttura e piano in ceramica C3  
Structure and top in ceramic C3

## Art. 10-65-02

Tavolo **60x40 cm / 80x30 cm** - altezza **30 cm** per tavolo fisso  
Colore ceramica categorie C1-C2-C3

---

Table **60x40 cm / 80x30 cm** - height **30 cm** for fixed table  
Ceramic color categoris C1-C2-C3

Struttura e piano in ceramica C1  
Structure and top in ceramic C1

Struttura e piano in ceramica C2  
Structure and top in ceramic C2

Struttura e piano in ceramica C3  
Structure and top in ceramic C3

## Art. 10-65-03

Tavolo **60x40 cm / 80x30 cm** - altezza **40 cm** per tavolo fisso  
Colore ceramica categorie C1-C2-C3

---

Table **60x40 cm / 80x30 cm** - height **40 cm** for fixed table  
Ceramic color categoris C1-C2-C3

Struttura e piano in ceramica C1  
Structure and top in ceramic C1

Struttura e piano in ceramica C2  
Structure and top in ceramic C2

Struttura e piano in ceramica C3  
Structure and top in ceramic C3



CUBE



# CORNER

Art. 10-70

Un tavolino unico nel suo genere, elegante e senza tempo, interamente fatto a mano con una cura e una precisione artigianale, estremamente adattabile a qualsiasi ambiente, grazie alla sua versatilità compositiva sia nella disposizione che nella scelta dei materiali.

A one-of-a-kind coffee table, elegant and timeless, entirely handmade with artisanal care and precision, extremely adaptable to any environment, thanks to its compositional versatility both in the arrangement and in the choice of materials.

## Art. 10-70-01

Tavolo **45x45 cm** - altezza **35 cm** per tavolo fisso

Colore marmo naturale categorie M1-M2-M3-M4 o Agglomerato Terrazzo T1

---

Table **45x45 cm** - height **35 cm** for fixed table

Marbre color categoris M1-M2-M3-M4 or Agglomerate Terrazzo T1

Struttura e piano in marmo naturale M1

Structure and top in natural marble M1

Struttura e piano in marmo naturale M2 o T1

Structure and top in natural marble M2 or T1

Struttura e piano in marmo naturale M3

Structure and top in natural marble M3

Struttura e piano in marmo naturale M4

Structure and top in natural marble M4

## Art. 10-70-02

Tavolo **60x60 cm** - altezza **40 cm** per tavolo fisso

Colore marmo naturale categorie M1-M2-M3-M4 o Agglomerato Terrazzo T1

---

Table **60x60 cm** - height **40 cm** for fixed table

Marbre color categoris M1-M2-M3-M4 or Agglomerate Terrazzo T1

Struttura e piano in marmo naturale M1

Structure and top in natural marble M1

Struttura e piano in marmo naturale M2 o T1

Structure and top in natural marble M2 or T1

Struttura e piano in marmo naturale M3

Structure and top in natural marble M3

Struttura e piano in marmo naturale M4

Structure and top in natural marble M4



## CORNER



# TRENDY

Art. 10-75

Un tavolino in ceramica caratterizzato da forme squadrate, realizzato interamente a mano e dal design unico ed elegante. Il gioco di dimensioni e altezze rende questo complemento di arredo il fulcro del vostro spazio, unendo modernità e raffinatezza.

A ceramic coffee table characterized by square shapes, entirely handmade and with a unique and elegant design. The play of dimensions and heights makes this furnishing accessory the fulcrum of your space, combining modernity and refinement.

## Art. 10-75-01

Tavolo **60x60 cm** - altezza **40 cm** per tavolo fisso  
Colore ceramica categorie C1-C2-C3

---

Table **60x60 cm** - height **40 cm** for fixed table  
Ceramic color categoris C1-C2-C3

Struttura e piano in ceramica C1  
Structure and top in ceramic C1

Struttura e piano in ceramica C2  
Structure and top in ceramic C2

Struttura e piano in ceramica C3  
Structure and top in ceramic C3

## Art. 10-75-02

Tavolo **100x50 cm** - altezza **40 cm** per tavolo fisso  
Colore ceramica categorie C1-C2-C3

---

Table **100x50 cm** - height **40 cm** for fixed table  
Ceramic color categoris C1-C2-C3

Struttura e piano in ceramica C1  
Structure and top in ceramic C1

Struttura e piano in ceramica C2  
Structure and top in ceramic C2

Struttura e piano in ceramica C3  
Structure and top in ceramic C3

## Art. 10-75-03

Tavolo **120x60 cm** - altezza **40 cm** per tavolo fisso  
Colore ceramica categorie C1-C2-C3

---

Table **120x60 cm** - height **40 cm** for fixed table  
Ceramic color categoris C1-C2-C3

Struttura e piano in ceramica C1  
Structure and top in ceramic C1

Struttura e piano in ceramica C2  
Structure and top in ceramic C2

Struttura e piano in ceramica C3  
Structure and top in ceramic C3



TRENDY





# Sedie Chairs

2025

---

## Maple art. 20-15-01

Sedia imbottita con struttura in legno di faggio tinto  
Upholstered chair with stained beech wood frame

Tessuti Seduta cat. A - B  
Seat Fabrics cat. A - B

Tessuti Seduta cat. C  
Seat Fabrics cat. C

Puntale galvanizzato oro  
Gold plated tip

### Scegli il tuo stile - Choose your style

Colori Struttura - essenze legno sedie  
Structure Colors - Wood essences chairs .....pag. 145

Colori Seduta e Schienale - tessuti sedie  
Seat and Backrest Colors - Chair Fabrics.....pag. 146 - 150

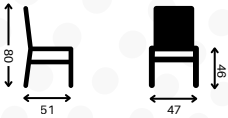

## Maple Armchair art. 20-15-02

Poltroncina imbottita struttura in legno di faggio tinto  
Padded armchair with stained beech wood frame

Tessuti Seduta cat. A - B  
Seat Fabrics cat. A - B

Tessuti Seduta cat. C  
Seat Fabrics cat. C

Puntale galvanizzato oro  
Gold plated tip

### Scegli il tuo stile - Choose your style

Colori Struttura - essenze legno sedie  
Structure Colors - Wood essences chairs .....pag. 145

Colori Seduta e Schienale - tessuti sedie  
Seat and Backrest Colors - Chair Fabrics.....pag. 146 - 150

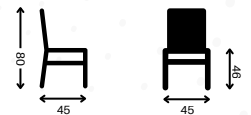

## Maple Wood art. 20-15-03

Sedia con seduta imbottita, struttura e schienale in legno di faggio tinto.  
Chair with padded seat, frame and backrest in stained beech wood.

Tessuti Seduta cat. A - B  
Seat Fabrics cat. A - B

Tessuti Seduta cat. C  
Seat Fabrics cat. C

Puntale galvanizzato oro  
Gold plated tip

### Scegli il tuo stile - Choose your style

Colori Struttura e Schienale - essenze legno sedie  
Structure and Backrest Colors - Wood essences chairs .....pag. 145

Colori Seduta - tessuti sedie  
Seat Colors - Chair Fabrics.....pag. 146 - 150

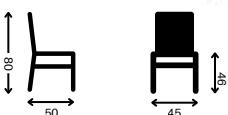



## Maple Armchair Wood

art. 20-15-04

Poltroncina con seduta imbottita, struttura e schienale in legno di faggio tinto  
 Armchair with padded seat, frame and backrest in stained beech wood

Tessuti Seduta cat. A - B  
 Seat Fabrics cat. A - B

Tessuti Seduta cat. C  
 Seat Fabrics cat. C

Puntale galvanizzato oro  
 Gold plated tip

### Scegli il tuo stile - Choose your style

Colori Struttura e Schienale - essenze legno sedie  
 Structure and Backrest Colors - Wood essences chairs .....pag. 145

Colori Seduta - tessuti sedie  
 Seat Colors - Chair Fabrics.....pag. 146 - 150

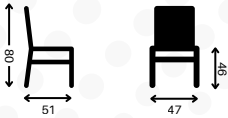

## Pine Wood

art. 20-20-01

Sedia con telaio in ferro verniciato, seduta e schienale in legno di faggio tinto  
 Chair with painted iron frame, seat and backrest in stained beech wood

Essenze Legno sedie  
 Wood Essenze chairs

### Scegli il tuo stile - Choose your style

Colori Struttura - Ral standard  
 Structure Colors - Ral standard .....pag. 144

Colori Seduta e Schienale - Essenze legno sedie  
 Seat and Backrest Colors - Wood essence chairs.....pag. 145

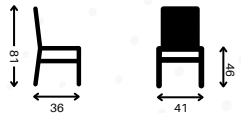

## Pine

art. 20-20-02

Sedia con telaio in ferro verniciato, seduta e schienale imbottiti  
 Chair with painted iron frame, padded seat and back

Tessuti Seduta cat. A - B  
 Seat Fabrics cat. A - B

Tessuti Seduta cat. C  
 Seat Fabrics cat. C

### Scegli il tuo stile - Choose your style

Colori Struttura - Ral standard  
 Structure Colors - Ral standard .....pag. 144

Colori Seduta e Schienale - tessuti sedie  
 Seat and Backrest Colors - Chair Fabrics.....pag. 146 - 150

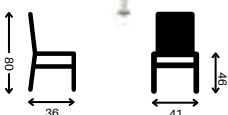



## Poplar art. 20-25-01

Poltroncina con struttura in ferro verniciato e legno di faggio tinto, seduta e schienale imbottiti

Armchair with painted iron frame and stained beech wood, padded seat and backrest

Tessuti Seduta cat. A - B  
Seat Fabrics cat. A - B

Tessuti Seduta cat. C  
Seat Fabrics cat. C

### Scegli il tuo stile - Choose your style

Colori Struttura - Ral standard  
Structure Colors - Ral standard .....pag. 144

Colori Seduta - tessuti sedie  
Seat Colors - Chair Fabrics.....pag. 146 - 150

Colori Schienale - Essenze legno sedie  
Back Colors - Wood essence chairs.....pag. 145

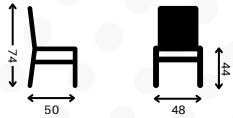

## Poplar Metal art. 20-25-02

Poltroncina con struttura, seduta e schienale in ferro verniciato  
Armchair with structure, seat and backrest in painted iron



Ral Standard  
Ral Standard

### Scegli il tuo stile - Choose your style

Colori Struttura - Ral standard  
Structure Colors - Ral standard .....pag. 144

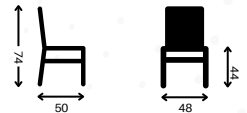

## Poplar Soft art. 20-25-03

Sedia con struttura in ferro verniciato, seduta imbottita e schienale in legno di faggio tinto

Chair with painted iron frame, padded seat and backrest in stained beech wood

Tessuti Seduta cat. A - B  
Seat Fabrics cat. A - B

Tessuti Seduta cat. C  
Seat Fabrics cat. C

### Scegli il tuo stile - Choose your style

Colori Struttura - Ral standard  
Structure Colors - Ral standard .....pag. 144

Colori Seduta - tessuti sedie  
Seat Colors - Chair Fabrics.....pag. 146 - 150

Colori Schienale - Essenze legno sedie  
Back Colors - Wood essence chairs.....pag. 145

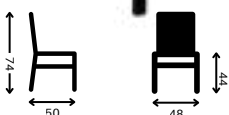



## Poplar Metal Soft

art. 20-25-04

Poltroncina con struttura e schienale in ferro verniciato, seduta imbottita  
Chair with painted iron frame, padded seat and backrest in stained beech wood

Tessuti Seduta cat. A - B  
Seat Fabrics cat. A - B

Tessuti Seduta cat. C  
Seat Fabrics cat. C

### Scegli il tuo stile - Choose your style

Colori Struttura - Ral standard  
Structure Colors - Ral standard .....pag. 144  
Colori Seduta - tessuti sedie  
Seat Colors - Chair Fabrics.....pag. 146 - 150

## Poplar Wood\_B

art. 20-25-05

Poltroncina con struttura in ferro verniciato, seduta e schienale in legno di faggio tinto  
Armchair with painted iron frame, seat and backrest in stained beech wood

Essenze legno sedie  
Wood essence chairs

### Scegli il tuo stile - Choose your style

Colori Struttura - Ral standard  
Structure Colors - Ral standard .....pag. 144  
Colori Seduta e Schienale - Essenze legno sedie  
Seat and Backrest Colors - Wood essence chairs .....pag. 145

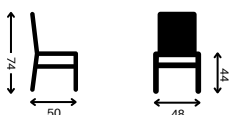
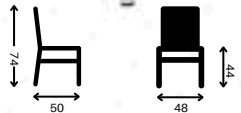

## Poplar Wood

art. 20-25-06

Sedia con struttura in ferro verniciato, seduta e schienale in legno di faggio tinto  
Chair with painted iron frame, seat and backrest in stained beech wood

Essenze legno sedie  
Wood essence chairs

### Scegli il tuo stile - Choose your style

Colori Struttura - Ral standard  
Structure Colors - Ral standard .....pag. 144  
Colori Seduta e Schienale - Essenze legno sedie  
Seat and Backrest Colors - Wood essence chairs .....pag. 145

## Palm art. 20-30-01

Sedia con struttura e schienale in legno di faggio tinto e seduta imbottita  
Chair with structure and backrest in stained beech wood and padded seat

Tessuti Seduta cat. A - B  
Seat Fabrics cat. A - B

Tessuti Seduta cat. C  
Seat Fabrics cat. C

Puntale galvanizzato oro  
Gold plated tip

### **Scegli il tuo stile - Choose your style**

Colori Struttura - Essenze legno sedie  
Structure Colors - Wood essence chairs.....pag. 145

Colori Seduta - tessuti sedie  
Seat Colors - Chair Fabrics.....pag. 146 - 150

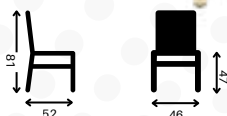

## Palm Armchair art. 20-30-02

Poltroncina con struttura e schienale in legno di faggio tinto e seduta imbottita  
Armchair with structure and backrest in stained beech wood and padded seat

Tessuti Seduta cat. A - B  
Seat Fabrics cat. A - B

Tessuti Seduta cat. C  
Seat Fabrics cat. C

Puntale galvanizzato oro  
Gold plated tip

### **Scegli il tuo stile - Choose your style**

Colori Struttura - Essenze legno sedie  
Structure Colors - Wood essence chairs.....pag. 145

Colori Seduta - tessuti sedie  
Seat Colors - Chair Fabrics.....pag. 146 - 150

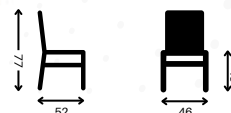

## Palm Tissue art. 20-30-03

Poltroncina imbottita con gambe in legno di faggio tinto  
Padded armchair with legs in stained beech wood

Tessuti Seduta cat. A - B  
Seat Fabrics cat. A - B

Tessuti Seduta cat. C  
Seat Fabrics cat. C

Puntale galvanizzato oro  
Gold plated tip

### **Scegli il tuo stile - Choose your style**

Colori Struttura - Essenze legno sedie  
Structure Colors - Wood essence chairs.....pag. 145

Colori Seduta e Schienale - tessuti sedie  
Seat and Backrest Colors - Chair Fabrics.....pag. 146 - 150

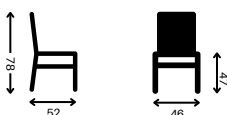

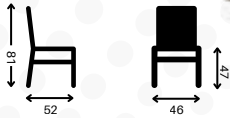

## Willow

art. 20-35-01

Sedia imbottita con gambe in legno di faggio tinto  
Upholstered chair with legs instained beech wood

Tessuti Seduta cat. A - B  
Seat Fabrics cat. A - B

Tessuti Seduta cat. C  
Seat Fabrics cat. C

Puntale galvanizzato oro  
Gold plated tip

### **Scegli il tuo stile - Choose your style**

Colori Struttura - Essenze legno sedie  
Structure Colors - Wood essence chairs.....pag. 145

Colori Seduta Schienale - tessuti sedie  
Seat and Backrest Colors - Chair Fabrics.....pag. 146 - 150

## Willow Armchair

art. 20-35-02

Poltroncina imbottita con gambe in legno di faggio tinto  
Padded armchair with legs in stained beech wood

Tessuti Seduta cat. A - B  
Seat Fabrics cat. A - B

Tessuti Seduta cat. C  
Seat Fabrics cat. C

Puntale galvanizzato oro  
Gold plated tip

### **Scegli il tuo stile - Choose your style**

Colori Struttura - Essenze legno sedie  
Structure Colors - Wood essence chairs.....pag. 145

Colori Seduta e Schienale - tessuti sedie  
Seat and Backrest Colors - Chair Fabrics.....pag. 146 - 150

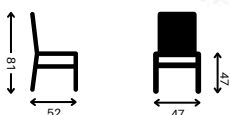
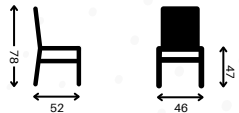

## Medlar

art. 20-35-03

Poltroncina imbottita con gambe in legno di faggio tinto  
Padded armchair with legs in stained beech wood

Tessuti Seduta cat. A - B  
Seat Fabrics cat. A - B

Tessuti Seduta cat. C  
Seat Fabrics cat. C

Puntale galvanizzato oro  
Gold plated tip

### **Scegli il tuo stile - Choose your style**

Colori Struttura - Essenze legno sedie  
Structure Colors - Wood essence chairs.....pag. 145

Colori Seduta e Schienale - tessuti sedie  
Seat and Backrest Colors - Chair Fabrics.....pag. 146 - 150



## Cypress art. 20-40-01

Sedia con telaio in ferro verniciato seduta e schienale imbottiti  
 Chair with painted iron frame padded seat and back

Tessuti Seduta cat. A - B  
 Seat Fabrics cat. A - B

Tessuti Seduta cat. C  
 Seat Fabrics cat. C

### Scegli il tuo stile - Choose your style

Colori Struttura - Ral standard  
 Structure Colors - Ral standard.....pag. 144

Colori Seduta e Schienale - tessuti sedie  
 Seat and Backrest Colors - Chair Fabrics.....pag. 146 - 150

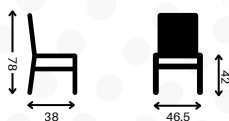

## Cypress Alum art. 20-40-02

Sedia con telaio in ferro, seduta e schienale in alluminio verniciato  
 con bottoni cromati/verniciati/galvanizzati

Chair with iron frame, seat and backrest in painted aluminum  
 with buttons chromed/painted/galvanized

Ral Standard  
 Ral Standard



### Scegli il tuo stile - Choose your style

Colori Struttura - Ral standard  
 Structure Colors - Ral standard.....pag. 144

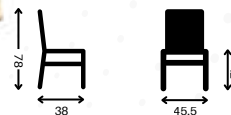

## Cypress Wood art. 20-40-03

Sedia con telaio in ferro verniciato seduta e schienale in legno  
 di faggio tinto

Chair with painted iron frame seat and backrest in stained beech wood

Seduta - essenze legno  
 Sitting - Wood essences chairs

### Scegli il tuo stile - Choose your style

Colori Struttura - Ral standard  
 Structure Colors - Ral standard.....pag. 144

Colori Seduta e Schienale - Essenze legno sedie  
 Seat and Backrest Colors - Wood essence chairs.....pag. 145

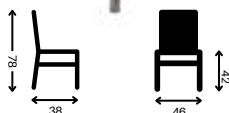



## Cypress B

art. 20-40-04

Sedia con braccioli con telaio in ferro verniciato, seduta e schienale imbottiti  
 Armchair with painted iron frame, padded seat and backrest

Tessuti Seduta cat. A - B  
 Seat Fabrics cat. A - B

Tessuti Seduta cat. C  
 Seat Fabrics cat. C

### Scegli il tuo stile - Choose your style

Colori Struttura - Ral standard  
 Structure Colors - Ral standard.....pag. 144

Colori Seduta e Schienale - tessuti sedie  
 Seat and Backrest Colors - Chair Fab.....pag. 146 - 150

## Cypress Alum B

art. 20-40-05

Sedia con braccioli con telaio in ferro verniciato, schienale e seduta in alluminio con bottoni cromati/verniciati/galvanizzati

Armchair with painted iron frame, backrest and seat in aluminum with chromed/painted/galvanized buttons

Ral Standard  
 Ral Standard

### Scegli il tuo stile - Choose your style

Colori Struttura - Ral standard  
 Structure Colors - Ral standard.....pag. 144

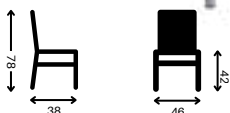
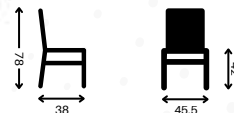

## Cypress Wood B

art. 20-40-06

Sedia con braccioli con telaio in ferro verniciato, seduta e schienale in legno di faggio tinto

Armchair with painted iron frame, seat and backrest in stained beech wood

Seduta - essenze legno  
 Sitting - Wood essences chairs

### Scegli il tuo stile - Choose your style

Colori Struttura - Ral standard  
 Structure Colors - Ral standard.....pag. 144

Colori Seduta e Schienale - Essenze legno sedie  
 Seat and Backrest Colors - Wood essence chairs.....pag. 145

## Mimosa art. 20-45-01

Sedia con telaio in ferro verniciato e seduta in legno di faggio tinto  
Chair with painted iron frame and stained beech wood seat

Essenze legno sedie  
Wood essence chairs

### Scegli il tuo stile - Choose your style

Colori Struttura - Ral standard  
Structure Colors - Ral standard .....pag. 144

Colori Seduta - Essenze legno  
Seat Colors - Wood essence chairs.....pag. 145

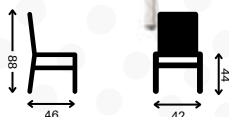

## Mimosa Soft art. 20-45-02

Sedia con telaio in ferro verniciato e seduta imbottita  
Chair with painted iron frame and padded seat

Tessuti Seduta cat. A - B  
Seat Fabrics cat. A - B

Tessuti Seduta cat. C  
Seat Fabrics cat. C

### Scegli il tuo stile - Choose your style

Colori Struttura - Ral standard  
Structure Colors - Ral standard .....pag. 144

Colori Seduta - Tessuti sedie  
Seat Colors - Chair Fabrics.....pag. 146 - 150

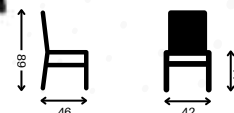

## Mimosa B art. 20-45-03

Sedia con braccioli con telaio in ferro verniciato e seduta in legno di faggio tinto  
Armchair with painted iron frame and seat in stained beech wood

Essenze legno sedie  
Wood essence chairs

Essenze legno sedie  
Wood essence chairs

### Scegli il tuo stile - Choose your style

Colori Struttura - Ral standard  
Structure Colors - Ral standard .....pag. 144

Colori Seduta - Essenze legno sedie  
Seat Colors - Wood essence chairs.....pag. 145

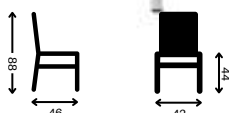



## Mimosa Soft B

art. 20-45-04

Sedia con braccioli con telaio in ferro verniciato e seduta imbottita  
Armchair with painted iron frame and padded seat

Tessuti Seduta cat. A - B  
Seat Fabrics cat. A - B

Tessuti Seduta cat. C  
Seat Fabrics cat. C

### Scegli il tuo stile - Choose your style

Colori Struttura - Ral standard

Structure Colors - Ral standard .....pag. 144

Colori Seduta - Tessuti sedie

Seat Colors - Chair Fabrics.....pag. 146 - 150

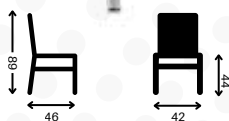

## Ginger

art. 20-50-01

Sedia con telaio in ferro verniciato e seduta in legno di faggio tinto  
Chair with painted iron frame and stained beech wood seat

Seduta - essenze legno  
Sitting - Wood essences chairs

### Scegli il tuo stile - Choose your style

Colori Struttura - Ral standard

Structure Colors - Ral standard .....pag. 144

Colori Seduta - Essenze legno

Seat Colors - Wood essence chairs.....pag. 145

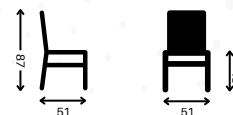

Opzione Puntale  
Galvanizzato Oro



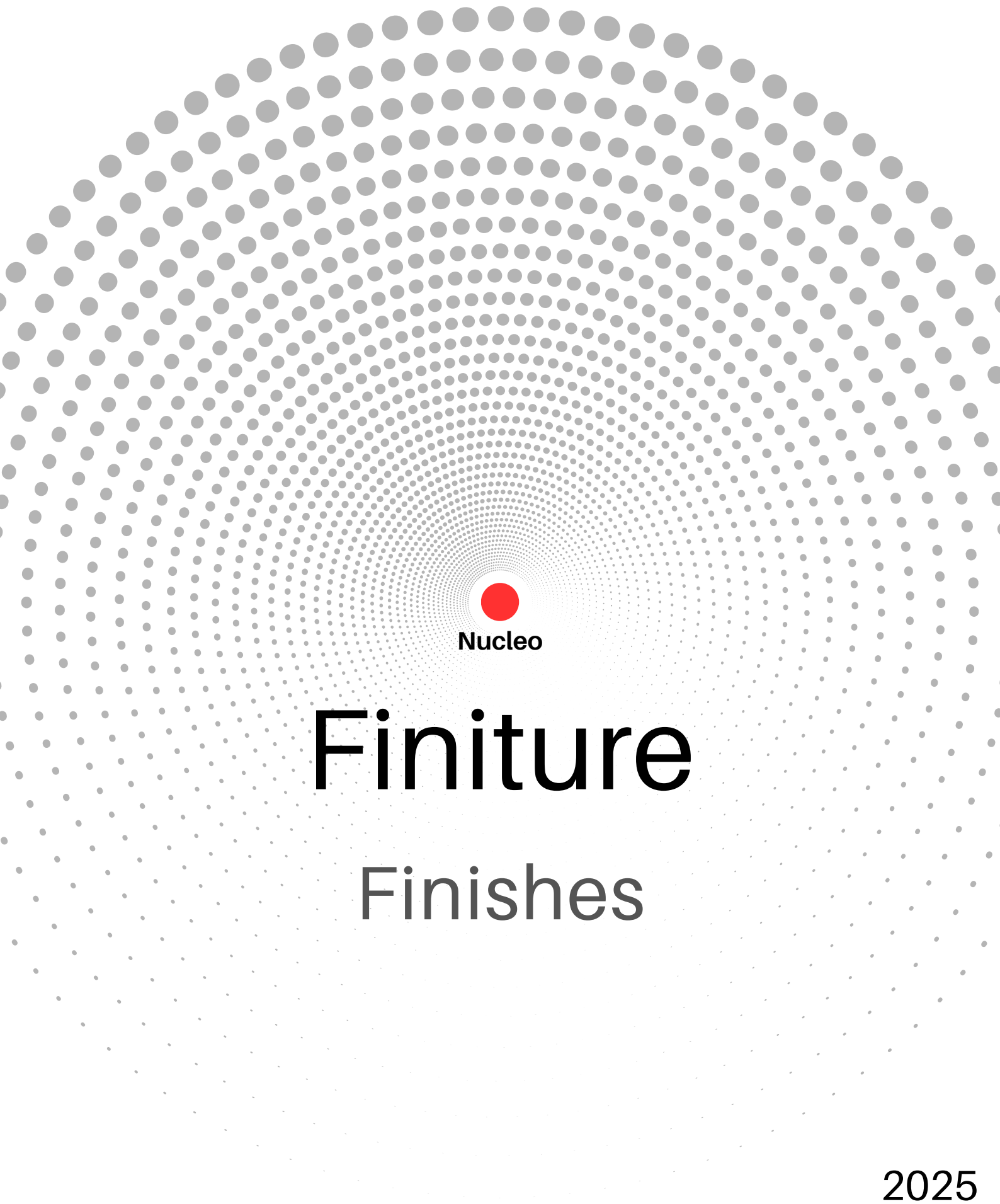

Nucleo

# Finiture

## Finishes

2025

---

# AGGLOMERATO TERRAZZO

## AGGLOMERATE TERRAZZO

Lucido o Opaco - Spessore 20 mm / Glossy or Matt - Thickness 20 mm

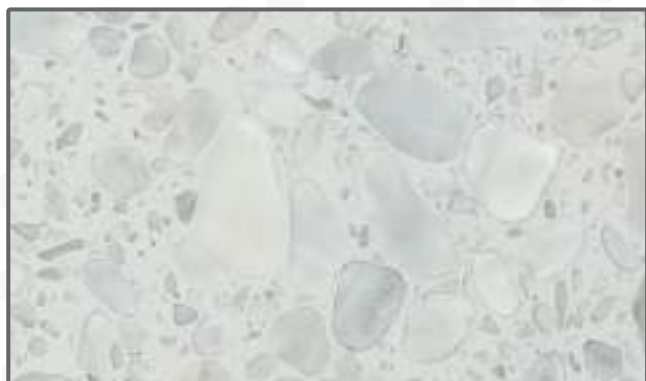

Palladio Bianco (T1)

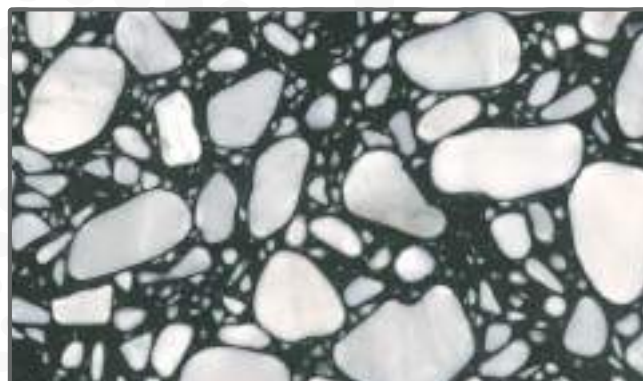

Palladio Nero (T1)



Arlecchino (T1)



Basel (T1)



Millennium (T1)



Perlato (T1)

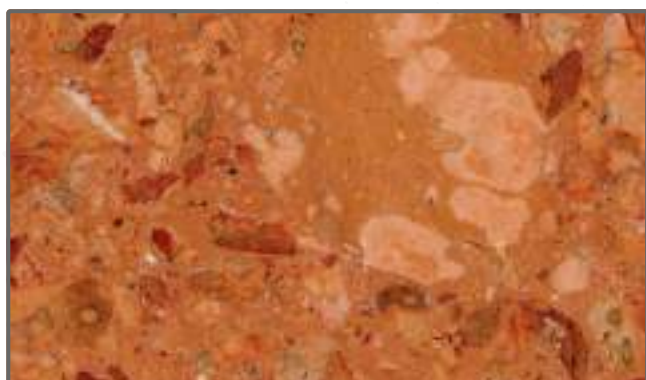

Rosso Asiago (T1)



Verde Italia (T1)

Per tavoli massimo 260x120 cm o Ø120 cm

# MARMO NATURALE NATURAL MARBLE

Lucido o Opaco - Spessore 20 mm / Glossy or Matt - Thickness 20 mm



Bianco Cristallino (M4)



Bianco di Carrara (M1)



Bianco Perla (M2)

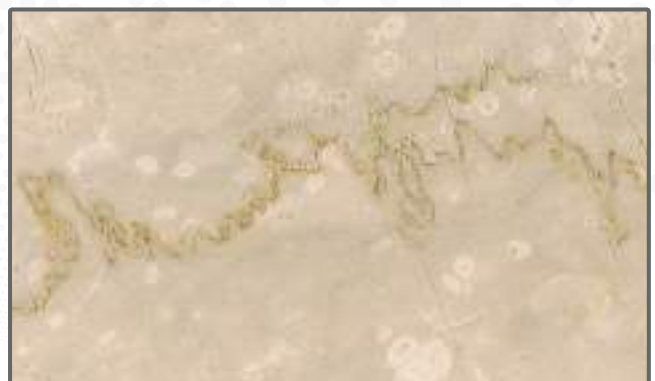

Botticino (M2)



Breccia Rosa (M3)



Calacatta (M4)



Daino Reale (M2)



Emperador Brown (M2)

# MARMO NATURALE

## NATURAL MARBLE

Lucido o Opaco - Spessore 20 mm / Glossy or Matt - Thickness 20 mm



Fior di Pesco (M3)



Nero Marquinia (M2)



Rosso Lepanto (M4)



Rosso Verona (M2)



Travertino Classico (M3)



Verde Alpi (M4)



Verde Guatemala (M2)



Arabescato (M4)

# QUARZO LUCIDO

## POLISHED QUARTZ

Spessore 20 mm / Thickness 20 mm

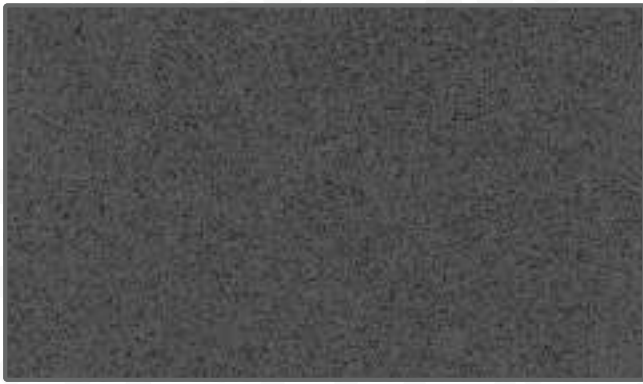

Antracite (Q1)



Bianco Assoluto (Q1)



Bianco Stellare (Q1)



Nero Assoluto (Q1)



Nero Stellare (Q1)



Noce (Q1)

# QUARZO LUCIDO

## POLISHED QUARTZ

Spessore 12 mm / Thickness 12 mm



Antracite (Q2)



Bianco Assoluto (Q3)



Bianco Stellare (Q3)



Grigio (Q2)

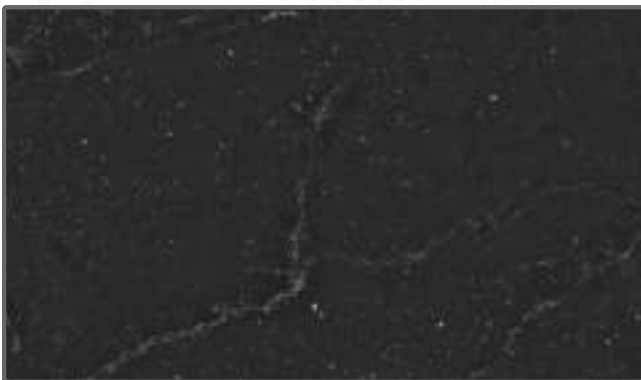

Romantic Ash (Q3)



Parisien Bleu (Q1)



SalePepe (Q2)

# QUARZO OPACO MATT QUARTZ

Spessore 12 mm / Thickness 12 mm



Brass Relish (Q3)



Chateau Brown (Q1)



Eclectic Pearl (Q1)



Lime Delight (Q3)



Night Tebas (Q3)

# CERAMICA OPACA

## MATT CERAMIC

Spessore 12 mm / Thickness 12 mm



Ardesia Grigia (C1)



Ardesia Nera (C1)



Grafite (C1)



Statuario Bianco (C1)



Travertino Gold (C1)



Verde Alpi (C1)



Nero Marquinia (C1)

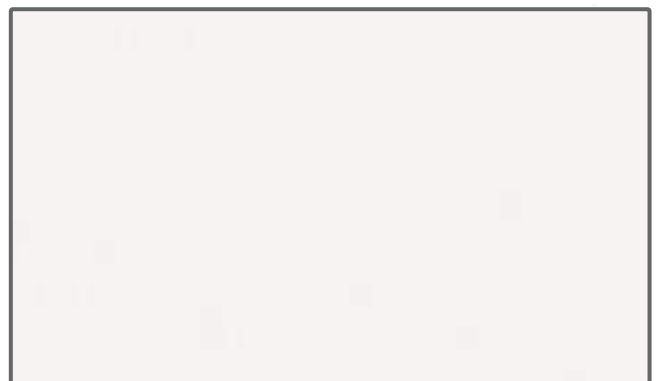

Bianco Naturale (C1)

# CERAMICA LUCIDA

## GLOSSY CERAMIC

Spessore 12 mm / Thickness 12 mm



Azzurro (C2)



Calacatta Oro (C2)



Nero Marquina (C2)



Port Laurent (C2)



Statuario Bianco (C2)

# CERAMICA MATERICA OPACA MATT MATERIAL CERAMIC

Spessore 12 mm / Thickness 12 mm



Pietra di Cardoso Grigio (C3)



Pietra di Cardoso Nero (C3)



Pietra Piasentina Grigio (C3)



Porfido Marrone (C3)

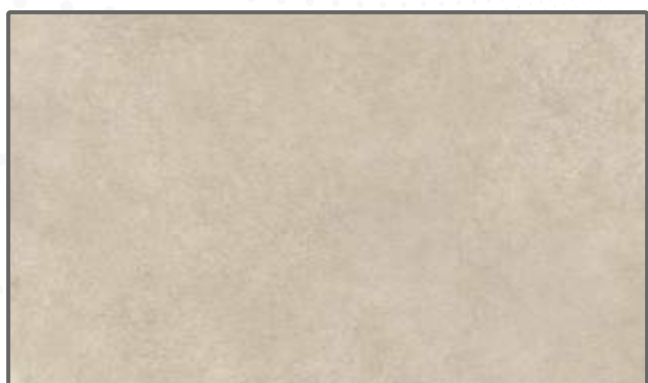

Terra di Matera (C3)



Terra di Saturnia (C3)



Terra di Pompei (C3)



Ceppo di Gré Grigio (C3)

# ESSENZE LEGNO

## WOOD ESSENCES

Per basi tavolo in legno - Escluso modello Tulipano  
For wooden table bases - Excluding Tulipano model



Naturale



Nero

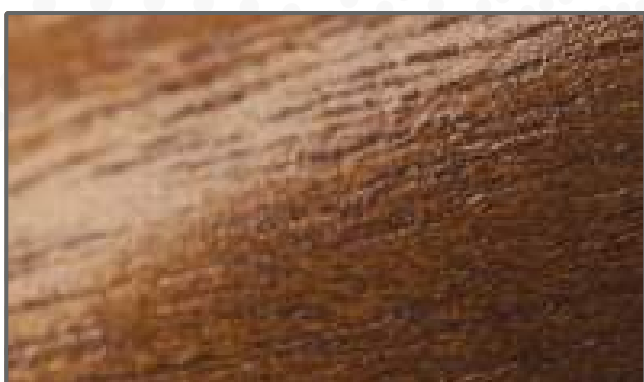

Noce Chiaro



Noce Scuro



Rovere

# COLORI RAL

## RAL COLORS

Per tavoli e sedie in metallo - Escluso modello Tulipano  
For metal tables and chairs - Excluding Tulipano model



Bronzo Metallizzato



Rame Metallizzato



Alluminio Goffrato



Avorio Opaco



Beige Grigio

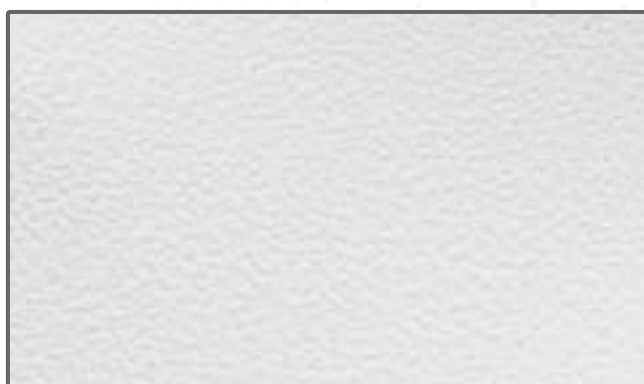

Bianco Bucciato



Nero Bucciato

# ESSENZE LEGNO SEDIE

## WOOD ESSENCES FOR CHAIRS



Bianco



Acero



Ciliegio Chiaro

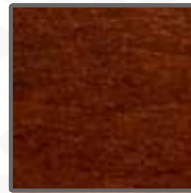

Ciliegio Scuro



Mogano Chiaro



Mogano



Naturale



Nero



Noce Chiaro



Noce Scuro



Noce



Palissandro



Rovere



Taupe

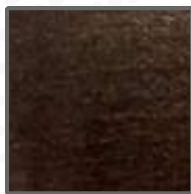

Wenge Rosso



Wenge

# RIVESTIMENTI CAT.A

## CAT.A COVERINGS

Cotone simil velluto

Velvet-like cotton



788-167



788-179



788-194



788-198

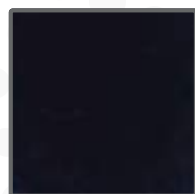

788-240



788-251



788-261



788-297



788-303



788-307



788-308

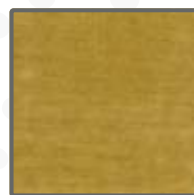

788-309

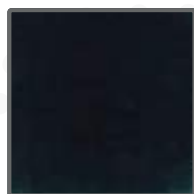

788-310



788-311



788-313



788-315



788-316



788-317



788-319



788-320



788-321

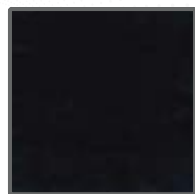

788-409



788-412



788-419



788-428



788-429



788-431

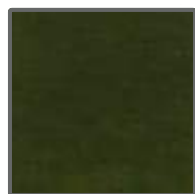

788-440



788-441



788-498



788-985

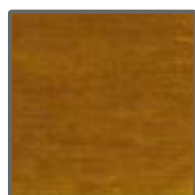

788-986



788-987

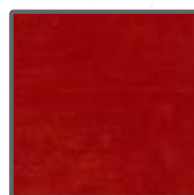

788-988

# RIVESTIMENTI CAT.A

## CAT.A COVERINGS

Cotone  
Cotton



780-033



780-035



780-002



780-004



780-007



780-008



780-010



780-030



780-031

# RIVESTIMENTI CAT.A

## CAT.A COVERINGS

Cotone  
Cotton



782-001



782-002



782-003



782-004



782-005



782-006



782-007



782-008



782-009



782-010



782-011

# RIVESTIMENTI CAT.B

## CAT.B COVERINGS

Cotone  
Cotton

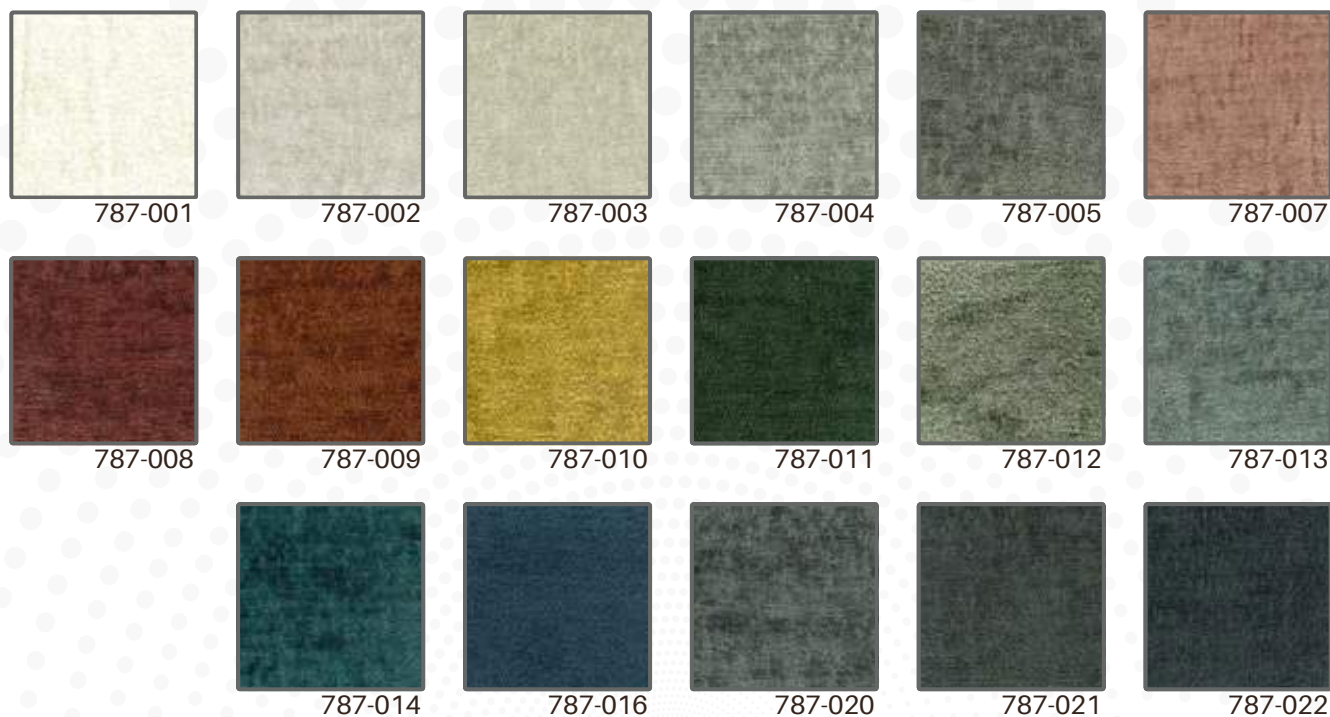

# RIVESTIMENTI CAT.B

## CAT.B COVERINGS

Cotone  
Cotton

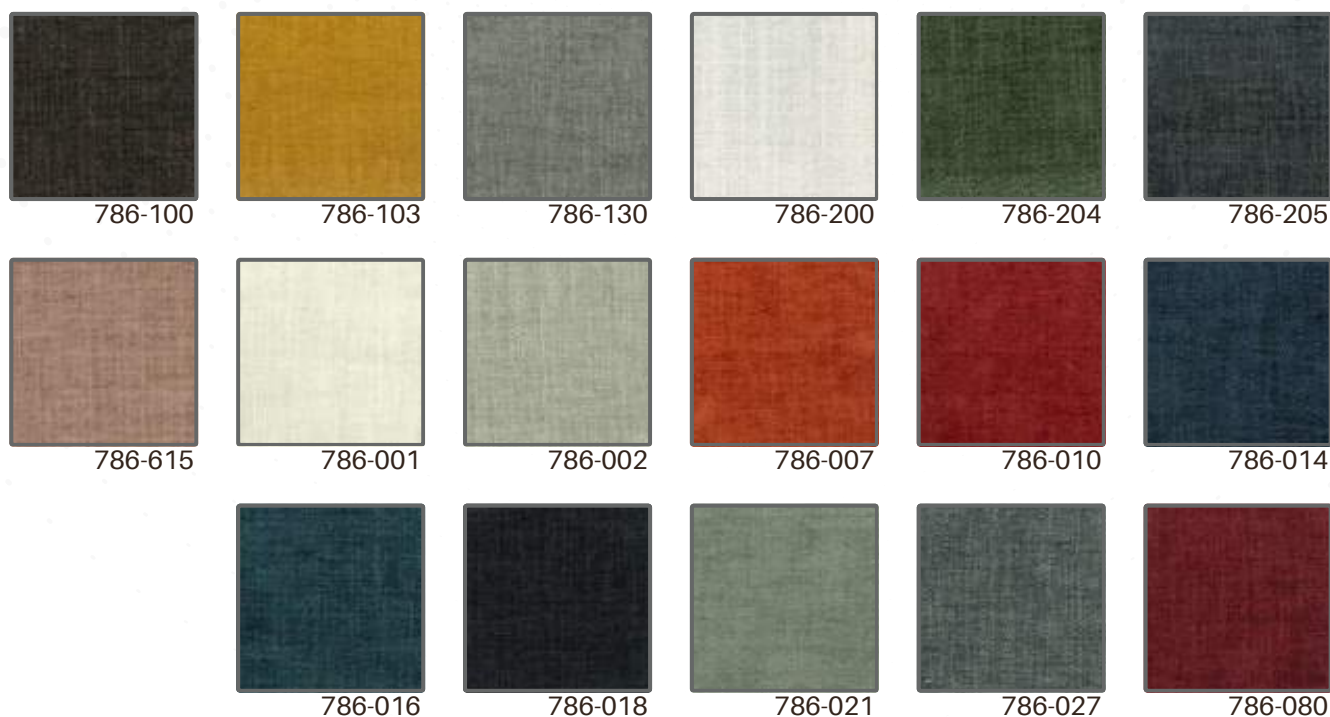

# RIVESTIMENTI CAT.B CAT.B COVERINGS

Cotone simil velluto  
Velvet-like cotton



784-007



784-010



784-012



784-015



784-017



784-018



784-020



784-027



784-102



784-130



784-615



784-800

# RIVESTIMENTI CAT.B CAT.B COVERINGS

Cotone  
Cotton



781-001



781-002



781-003



781-004



781-005



781-007



781-008



781-010

# RIVESTIMENTI CAT.C

## CAT.C COVERINGS

Similpelle Ignifuga  
Fireproof Faux Leather



# PROFILI TOP TAVOLO

## TABLE TOP EDGES

MARMO NATURALE e AGGLOMERATO TERRAZZO  
 NATURAL MARBLE and AGGLOMERATE TERRAZZO  
 Spessore 20 mm - Thickness 20 mm  
 LUCIDO o OPACO - GLOSSY or MATT

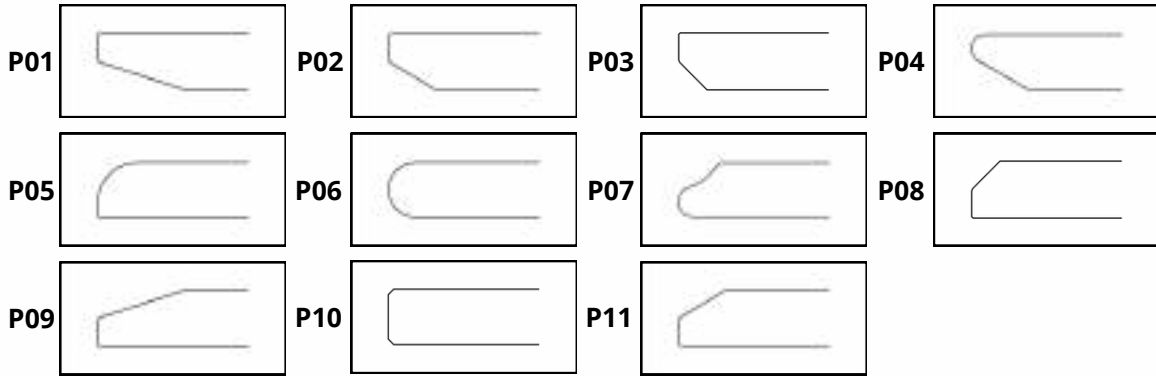

QUARZO - QUARTZ  
 Spessore 20 mm - Thickness 20 mm  
 LUCIDO - GLOSSY

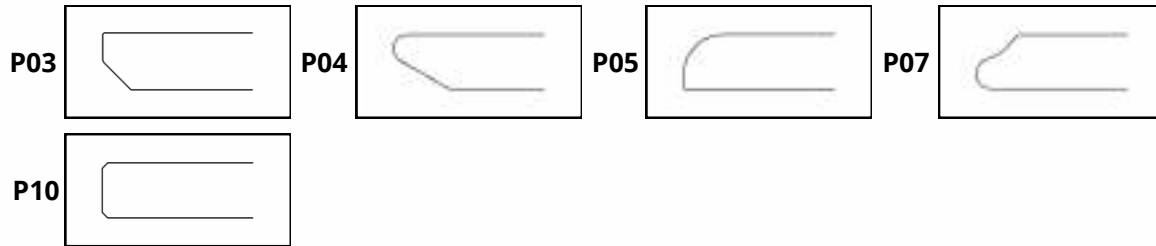

QUARZO - QUARTZ  
 Spessore 12 mm - Thickness 12 mm  
 LUCIDO - GLOSSY



CERAMICA - CERAMIC  
 Spessore 12 mm - Thickness 12 mm  
 LUCIDA o OPACA o MATERICA - GLOSSY or MATT or MATERIAL

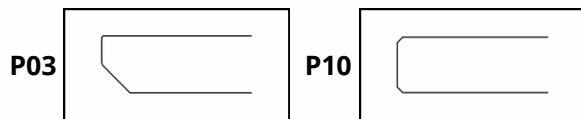





Tavolino STONE - pag. 108

# Cura e Manutenzione

Per la pulizia ordinaria, utilizzare esclusivamente panni morbidi e spugne non abrasive, inumiditi con acqua e/o detersivi neutri. È fondamentale evitare di graffiare la superficie e di impiegare detersivi eccessivamente aggressivi con pH estremamente alto o basso.

Si raccomanda di evitare prodotti contenenti alcol, acetone, ammoniaca, cloro, solventi, composti acidi e basici, poiché potrebbero ristagnare e macchiare o corrodere la superficie.

Mantenere lontani solventi per unghie, ammoniaca o detersivi contenenti ammoniaca, sbiancanti, pennarelli indelebili, inchiostro, saponi oleosi, limone, vino, caffè e bevande.

Qualora una delle sostanze sopra elencate dovesse entrare in contatto con la superficie, risciacquare e asciugare immediatamente.

Evitare bruciature da sigarette e non posizionare sulla superficie oggetti molto caldi o abrasivi.

Infine, smaltire il mobile seguendo le modalità e le procedure stabilite dall'azienda comunale competente per lo smaltimento.

# Care and Maintenance

For ordinary cleaning, use only soft cloths and non-abrasive sponges, moistened with water and/or neutral detergents. It is essential to avoid scratching the surface and using excessively aggressive detergents with extremely high or low pH.

It is recommended to avoid products containing alcohol, acetone, ammonia, chlorine, solvents, acidic and basic compounds, as they could stagnate and stain or corrode the surface.

Keep away nail polish removers, ammonia or detergents containing ammonia, whiteners, permanent markers, ink, oily soaps, lemon, wine, coffee and drinks.

If any of the substances listed above should come into contact with the surface, rinse and dry immediately.

Avoid cigarette burns and do not place very hot or abrasive objects on the surface.

Finally, dispose of the furniture following the methods and procedures established by the competent municipal waste disposal company.

## Note

Tutti i prezzi di questo catalogo sono da intendersi IVA esclusa.

Per consegna di ordini inferiori a € 1.000,00 iva esclusa sarà addebitato un contributo di trasporto di € 50,00 iva esclusa.

Le commesse sono sempre soggette all'approvazione dell'azienda, la quale può accettarle tacitamente o rifiutarle espressamente per iscritto entro dieci giorni dal ricevimento.

È fondamentale effettuare un controllo del materiale al momento dello scarico. Eventuali difformità riscontrate, attribuibili a fasi successive all'imballaggio (come rotture, ammaccature o graffiature), devono essere contestate immediatamente al trasportatore e annotate sul documento di trasporto, per poi essere comunicate all'azienda.

Non saranno accettate contestazioni successive, eccetto nel caso di evidenti difetti di fabbricazione riscontrati nel materiale. In tal caso, l'azienda provvederà alla sostituzione dopo che un suo incaricato avrà esaminato il prodotto contestato e verificato il difetto.

Non sono consentiti resi senza preventiva autorizzazione da parte dell'azienda.

Si respingono tutte le contestazioni relative alla tonalità e all'intensità delle venature dei top in marmo, ceramica e legno, poiché tali variazioni sono intrinseche ai materiali e naturali per loro natura.

Le immagini delle finiture e dei colori presentati devono essere considerate puramente indicative.

La nostra azienda si riserva il diritto di apportare modifiche a parti e dettagli in qualsiasi momento e senza preavviso, qualora ciò si renda necessario per migliorare la funzionalità o l'estetica dei prodotti.

## Note

All prices in this catalog are exclusive of VAT.

For delivery of orders under € 1,000.00 excluding VAT, a transport fee of € 50.00 excluding VAT will be charged.

Orders are always subject to the approval of the company, which can accept them tacitly or expressly reject them in writing within ten days of receipt.

It is essential to check the material upon unloading. Any discrepancies found, attributable to phases subsequent to packaging (such as breakages, dents or scratches), must be immediately contested to the carrier and noted on the transport document, and then communicated to the company.

Subsequent complaints will not be accepted, except in the case of obvious manufacturing defects found in the material. In this case, the company will replace the product after one of its representatives has examined the disputed product and verified the defect.

Returns are not permitted without prior authorization from the company.

All complaints relating to the shade and intensity of the grain of marble, ceramic and wood tops are rejected, as these variations are intrinsic to the materials and natural by their nature.

The images of the finishes and colors presented must be considered purely indicative.

Our company reserves the right to make changes to parts and details at any time and without notice, if this is necessary to improve the functionality or aesthetics of the products.





# NUCLEO

## I NOSTRI CONTATTI

Get in touch with Us!

 +39 051 827713

 [info@nucleoarreda.it](mailto:info@nucleoarreda.it)

 [www.nucleoarreda.it](http://www.nucleoarreda.it)

 [nucleo\\_arreda](https://www.instagram.com/nucleo_arreda)

 [nucleo](https://www.facebook.com/nucleo)



c/o Serra Marmi  
Via L. Davia 9/F  
San Giovanni in Persiceto, 40017  
Bologna, Italy